

# Specifications

## Technical Data

Parameter	Values
<b>SKU</b>	AS8000D
<b>Filter Dimensions</b>	114x133x9.5mm
<b>View Size</b>	100x83.4mm
<b>Arc Sensors</b>	4
<b>Classification</b>	1/1/1/1
<b>Light State</b>	4
<b>Dark State</b>	5-13
<b>UV/IR Protection</b>	DIN15
<b>Time from Light to Dark</b>	0.04ms
<b>Time from Dark to Light</b>	0.1-0.9s
<b>Sensitivity Delay</b>	Adjustable (1-5 for low-high)
<b>Power Supply</b>	Solar Cells & CR2450 Replaceable Battery
<b>Warranty</b>	3 Years
<b>Operating Temperature</b>	-10°C to 65°C
<b>Storage Temperature</b>	-20°C to 85°C
<b>Shade Control</b>	Yes
<b>Grind Mode</b>	Yes (External)
<b>Standards</b>	AS/NZS 1337.1 B (High Impact) AS/NZS 1338.1 (Auto-Darkening)

## Replaceable Parts

Part	SKU
<b>Inside Cover Lens 106x90mm 5 Pack</b>	XA-ICL106-90
<b>Front Cover Lens 133x114mm 5 Pack</b>	XA-FCL133-114
<b>4 Point Harness</b>	XA-AS-4-HB
<b>4 Point Harness Sweatband</b>	XA-AS-4-SWB
<b>4 Point Harness Back Pad</b>	XA-AS-4-BP
<b>Magnification Lens</b>	MWL4215 - 1.5x Magnification Lens MWL4220 - 2.0x Magnification Lens MWL4225 - 2.5x Magnification Lens

## Parts Breakdown

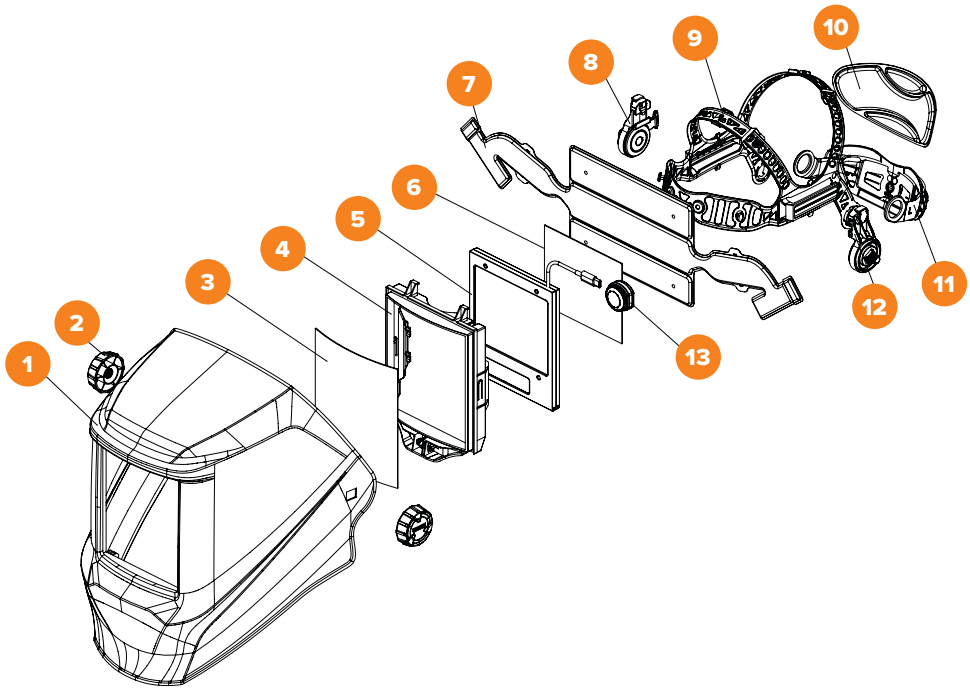

- |                                       |                                     |
|---------------------------------------|-------------------------------------|
| <b>1.</b> Helmet Shell                | <b>8.</b> Harness Bracket - Right   |
| <b>2.</b> Adjustment Knob             | <b>9.</b> 4 Point Harness           |
| <b>3.</b> Outer Lens Cover            | <b>10.</b> 4 Point Harness Back Pad |
| <b>4.</b> ADF Frame                   | <b>11.</b> Neck Band                |
| <b>5.</b> Auto-Darkening Filter (ADF) | <b>12.</b> Harness Bracket - Left   |
| <b>6.</b> Inner Lens Cover            | <b>13.</b> External Grind Button    |
| <b>7.</b> 4 Point Harness Sweatband   |                                     |