

XCEL-ARC



AS8000D

Operating Manual



Contents

1. Safety	3
2. Features	4
3. Specifications	5
4. Parts Breakdown	6
5. Operating Instructions	7
6. Harness Operating Instructions	12
7. Troubleshooting	14
8. Warranty	14
9. Shade Guide	15

1. Safety

Please read and understand all instructions before using.

- Be sure that the dark shade of the lens in the welding helmet is on the correct shade number for your application.
- The helmet and lenses are not suitable for “overhead” welding application, laser welding, or laser cutting applications.
- Welding helmets are designed to protect the eyes and face from sparks, spatter, and harmful radiation under normal welding conditions.
- This helmet will not protect against explosive devices or corrosive liquids. Machine guards or eye splash protection must be used when these hazards are present.
- Impact resistant, primary eye protection, spectacles or goggles that meet current ANSI specifications, must be worn at all times when using this welding helmet.
- Avoid work positions that could expose unprotected areas of the body to sparks, spatter, direct and/or reflected radiation. Use appropriate protection if exposure cannot be avoided.
- Before each use, check that the protection plates are clean and that no dirt is covering the sensors on the front of the lens.
- Inspect all operating parts before each use for signs of wear or damage. Any scratched, cracked, or pitted parts should be replaced immediately.
- Do not make any modifications to either the welding lens or helmet, other than those specified in this manual. Do not use any replacement parts other than those specified in this manual. Unauthorised modifications and replacement parts will void the warranty and expose the user to the risk of personal injury.
- If this lens does not darken when striking arc, stop welding immediately and check the helmet is in Weld Mode and not Grind Mode. If the issue persists, contact your local Xcel-Arc Service Department.
- Do not immerse this lens in water.
- Do not use any solvents on any lens or helmet components.
- The recommended operating temperature range for this welding lens is -10°C to 65°C (14°F-149°F). Do not use this device beyond these temperature limits.
- Failure to follow these warnings and/or failure to follow all of the operating instructions could result in severe personal injury.



WARNING: Contains button battery, hazardous if swallowed. Keep out of reach from children. Battery can cause severe or fatal injuries in 2 hours or less if it is swallowed or placed inside any part of the body. Medical attention should be sought immediately if it is suspected the battery has been swallowed or placed inside any part of the body.

2. Features

1/1/1/1 Classification

Superior optical clarity with a 1/1/1/1 classification. Get an Auto-Darkening Filter (ADF) that's scored top marks across the board for a crystal-clear view of your weld at every angle.

Memory States

Store up to three of your most frequently used shade settings with the memory state buttons and have your helmet ready to go in an instant.

100x83.4mm View Size

Superior visibility in every situation. The 100x83.4mm viewing area lets you see every weld with complete clarity.

External Grind Button

Seamlessly switch to grind mode with the click of a button. When the helmet is in grind mode a small LED will illuminate, so you don't need to take the helmet off to check.

4 Arc Sensors

Detect every arc instantly. The four optimally positioned arc sensors trigger the lens, darkening it and keeping your eyes shielded from the start, even when you're out of position.

Backup Battery

A CR2450 backup battery improves the performance and reliability of the auto-darkening filter.

4 Point Harness

Get the perfect fit and stay comfortable for hours. Adjust all 4 points of contact to suit you, and have the weight spread more evenly, minimising neck strain.

3. Specifications

3.1 Technical Data

Parameter	Values
SKU	AS8000D
Filter Dimensions	114x133x9.5mm
View Size	100x83.4mm
Arc Sensors	4
Classification	1/1/1/1
Light State	4
Dark State	5-13
UV/IR Protection	DIN15
Time from Light to Dark	0.04ms
Time from Dark to Light	0.1-0.9s
Sensitivity Delay	Adjustable (1-5 for low-high)
Power Supply	Solar Cells & CR2450 Replaceable Battery
Warranty	3 Years
Operating Temperature	-10°C to 65°C
Storage Temperature	-20°C to 85°C
Shade Control	Yes
Grind Mode	Yes (External)
Standards	AS/NZS 1337.1 B (High Impact) AS/NZS 1338.1 (Auto-Darkening)

3.2 Replaceable Parts

Part	SKU
Inside Cover Lens 106x90mm 5 Pack	XA-ICL106-90
Front Cover Lens 133x114mm 5 Pack	XA-FCL133-114
4 Point Harness	XA-AS-4-HB
4 Point Harness Sweatband	XA-AS-4-SWB
4 Point Harness Back Pad	XA-AS-4-BP
Magnification Lens	MWL4215 - 1.5x Magnification Lens MWL4220 - 2.0x Magnification Lens MWL4225 - 2.5x Magnification Lens

4. Parts Breakdown

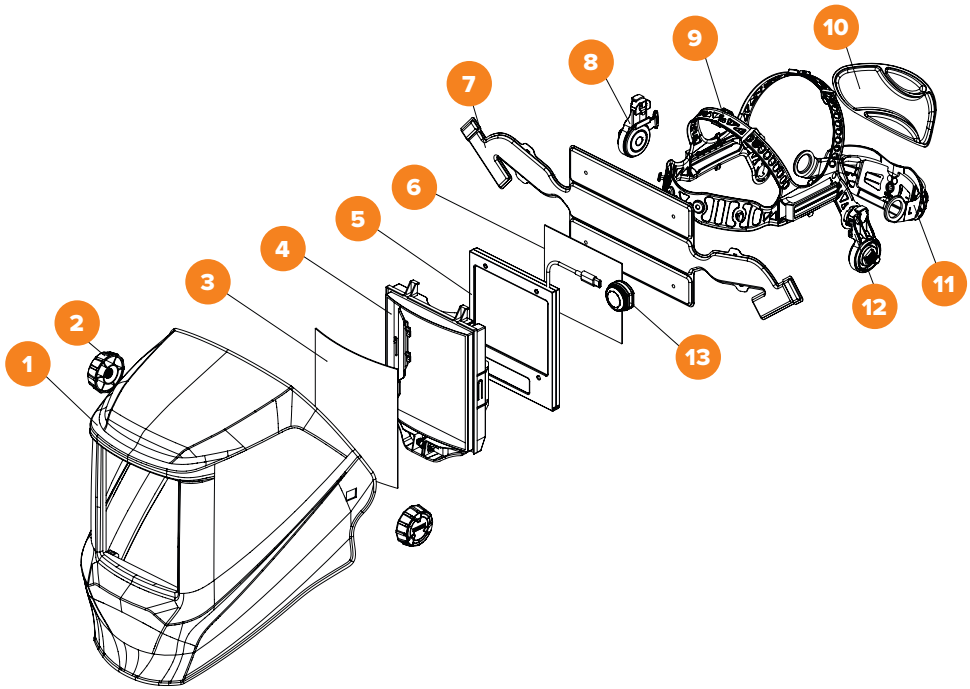

- | | |
|---------------------------------------|-------------------------------------|
| 1. Helmet Shell | 8. Harness Bracket - Right |
| 2. Adjustment Knob | 9. 4 Point Harness |
| 3. Outer Lens Cover | 10. 4 Point Harness Back Pad |
| 4. ADF Frame | 11. Neck Band |
| 5. Auto-Darkening Filter (ADF) | 12. Harness Bracket - Left |
| 6. Inner Lens Cover | 13. External Grind Button |
| 7. 4 Point Harness Sweatband | |

5. Operating Instructions



1. Shade Selector Button
2. Weld/Grind Mode Button
3. Sensitivity Button
4. Delay Button
5. ADF Display
6. Memory Buttons
7. External Grind Button



Manual Shade Control

Press the **Mode (2)** button once to activate the edit mode setting. The current mode icon will now flash. Then press **Mode (2)** button again to cycle to the desired mode. Available options are **Shade 5-9** [5-9], **Shade 9-13** [9-13] and **Grind** [GRIND]. Once desired mode is selected, wait 5s for the filter to exit edit mode and the selected mode icon will become solid.

In **Shade 5-9** [5-9] or **Shade 9-13** [9-13] the desired shade is selected by pressing the **Shade (1)** button. Press **Shade (1)** once to enter edit shade mode, and the current shade number will now flash. Then continue to press **Shade (1)** button until the desired shade (13) is shown. After waiting 5s, the ADF will exit edit shade mode and the shade number will become solid.

Note:

Choose an optimum shade number for the required welding process or application.

If this lens does not darken when striking an arc, stop welding immediately and check the helmet is in Weld Mode and not Grind Mode. If the issue persists, contact your local Xcel-Arc Service Department.

Sensitivity Control

The responsiveness to different light levels in various welding processes can be adjusted in the range 1-5 (from low to high).

Press the **Sensitivity Button (3)** to edit the setting, the current sensitivity level will flash on the screen (from 1 to 5). Repeatedly press the **Sensitivity Button (3)** until the desired level is shown.

Low Sensitivity

- Suitable for high amperage welding and welding in bright light conditions (lamp light or sunlight).

High Sensitivity

- Suitable for low amperage welding and use in poor light conditions.
- Suitable for use with steady arc process such as TIG welding.
- Under normal use, a higher sensitivity setting is recommended.

Delay Control

The length of time delay for the ADF to return to the light state after welding can be adjusted in the range 1-5 (0.1-0.9s). The time delay is for the protection of the welder's eyes from strong residual rays after welding.

Press the **Delay Button (4)** to edit the setting, the current delay level will flash on the screen (from 1 to 5). Repeatedly press the **Delay Button (4)** until the desired length of time delay is shown.

Low Delay



- The time the ADF takes to lighten after welding becomes shorter. The shortest time is about 0.1s depending on the welding point temperature and shade setting. This setting is ideal for tack welding or production welding with short welds.

High Delay

- The time the ADF takes to lighten after welding becomes longer. The longest time is about 0.9s depending on the welding point temperature and shade setting. This setting is ideal for welding at high amperage where there is an afterglow from the weld.

Grind Selection

There are two methods to activate Grind Mode on this ADF.

1. Press the **Mode (2)** button repeatedly to cycle to **Grind** 
2. Hold the **External Grind Button (7)** until the **Grind**  icon appears on the screen and the red light on the ADF button flashes. To exit grind mode, hold the **External Grind Button (7)** until the grind icon disappears.

Note: Do not weld in the grind mode, the ADF will not darken.

Memory State Settings

The three most frequently used settings can be stored and reactivated easily by using the three **Memory Buttons (6)**.

By default, this helmet will display your last used settings when it is turned on.

If you want to store a complete welding setting, press and hold one of the **Memory Buttons (6)**, the corresponding number will start flashing on screen for 2s and once the icon has gone solid, the memory setting has been saved.

To activate the stored memory setting, press the corresponding **Memory Button (6)**.

Note: Only in welding mode  can you activate the memory states. Change to welding mode if you are currently using the grinding function.

Battery Indicator

The battery icon will show current battery level. When low, the battery icon will show no bars. Replace the battery when it is low, otherwise the ADF switching time will become slower, and shade accuracy will be compromised.

Removing The ADF From The Helmet Shell

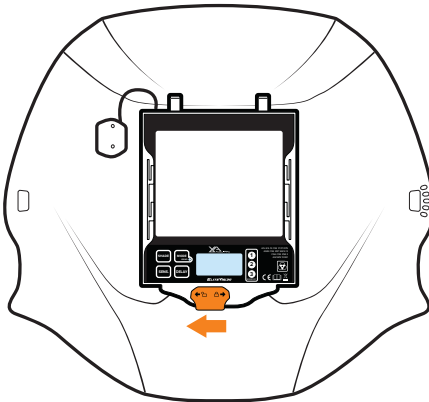

1. Switch the ADF frame lock to the left position to unlock it from the helmet shell.

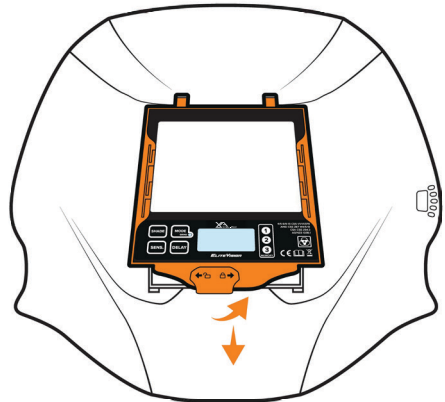

2. Lift the bottom of the ADF up then slide the unit down to remove it from the helmet shell.

Power Supply & Replacing The Battery

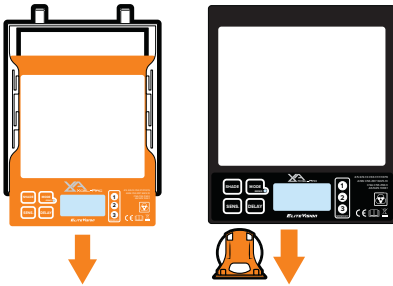

The power of the auto-darkening helmet is provided by solar cells and a CR2450 lithium battery. To change the batteries, remove the ADF from the ADF frame. The battery compartment is on the bottom of the ADF, open the compartment to replace the battery.

Changing The Inner Lens Cover

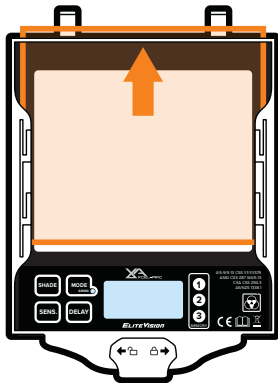

Pry the inner lens cover up from the finger groove at the top of the ADF. The inner lens cover can then slide up and out of the ADF. Replace with new inner lens cover.

Changing The Outer Lens Cover

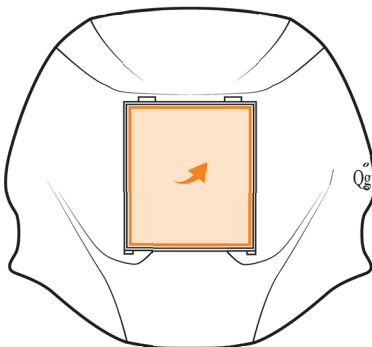

With the ADF frame removed, simply lift out the existing outer lens cover. Replace with new outer lens cover.

Installing A Magnification Lens

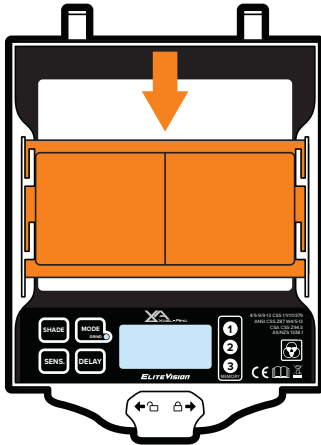

Slide the magnification lens down through the magnification lens holder.

Additional Instructions

- Be sure that the helmet is used in the correct condition and according to the safety requirements.
- There is a liquid crystal-valve in the filter, although it has inner and outer protection covers, it is important to avoid heavy knocks to the helmet.
- The outer protective shell of the helmet should be periodically inspected and cleaned. In the case of a break, crack, pitting or other damage, the helmet shell must be replaced.
- To operate more efficiently and safely, please select the correct dark shade number.
- The arc light must be visible completely by all arc sensors. If not, the ADF may struggle to detect an arc and may not activate the selected shade.
- Please use the automatic filter at a temperature between -10°C - 65°C (14°F - 149°F).
- Do not disassemble the filter. If any problems arise, please contact your local Xcel-Arc service department.

6. Harness Operating Instructions

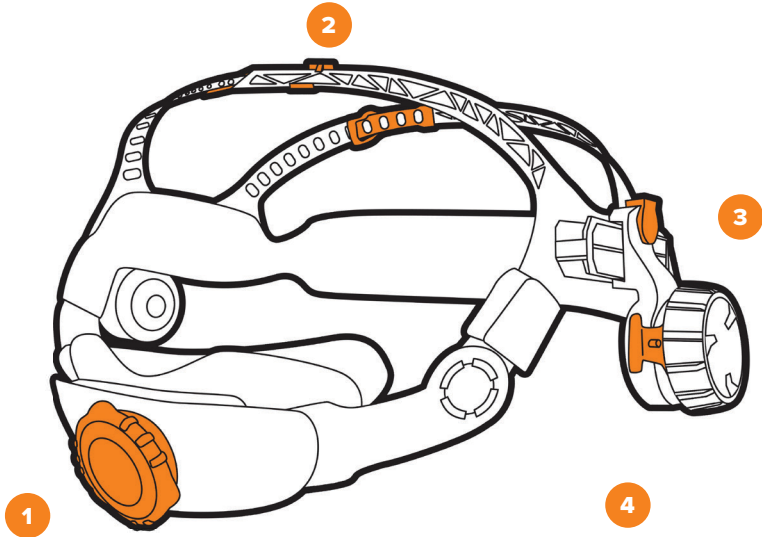

6.1 Neck Band Adjustment

To **tighten** the neck band, turn the neck band adjustment dial  clockwise .

To **loosen** the neck band, turn the neck band adjustment dial  anti-clockwise.

6.2 Head Strap Adjustment



To adjust the head straps, first push the head strap lock out of the current position. Then adjust the strap to the desired length, and push the head strap lock into the corresponding position.

6.3 Distance Adjustment



To adjust the distance between your face and the lens, push the distance adjuster buttons. The helmet shell can now move towards or away from your face. Release the buttons to lock the shell into position.

Ensure that both sides are equally positioned for proper vision.

6.4 Angle Adjustment



There are 5 positions available to set the angle of the helmet. To adjust, lift and reposition the locking tab into the desired angle position.

7. Troubleshooting

1. The ADF does not darken when welding

- Stop welding or cutting immediately.
- Make sure the sensors are facing the arc and there are no obstructions.
- Check the mode is on WELD, not GRIND.
- Review sensitivity recommendations and adjust sensitivity if possible.
- Replace the battery if necessary.

2. The ADF stays dark after welding or there is no arc present

- Adjust the sensitivity to a lower level.
- If the worksite is too bright, it is recommended to reduce the surrounding light level.

3. The ADF switches during welding

- Increase the sensitivity if possible.
- Make sure the sensors are facing the arc and there are no obstructions.
- Increasing Delay 0.1–0.3 seconds may also reduce switching.

8. Warranty

Xcel-Arc auto-darkening welding helmets are covered for warranty for up to three years from the date of purchase from authorised Xcel-Arc dealers. The duration of use depends on various factors such as use, cleaning storage and maintenance. Frequent inspections are recommended.

9. Shade Guide

MMA/STICK

Current	Shade
<40A	9
40-60A	10
60-175A	11
175-300A	12
300-500A	13
>500A	14

TIG

Current	Shade
<20A	9
20-40A	10
40-100A	11
100-175A	12
175-250A	13
>250A	14

MIG

Current	Shade
<100A	10
100-175A	11
175-300A	12
300-500A	13
>500A	14

Arc Gouging

Current	Shade
<175A	10
175-225A	11
225-275A	12
275-350A	13
350-450A	14
>450A	15

MAG

Current	Shade
<60A	10
60-125A	11
125-175A	12
175-300A	13
300-500A	14
>500A	15

Plasma Cutting

Current	Shade
<150A	11
150-250A	12
>250A	13



Esseti New Zealand Limited

PO Box 4189, Palmerston North - 4442

Phone: 06 355 1103

Email: sales@esseti.co.nz

www.esseti.co.nz

 New Zealand Owned |  www.xcelarc.nz |    @xcelarcnz

Xcel-Arc © Esseti NZ LTD - 2023