

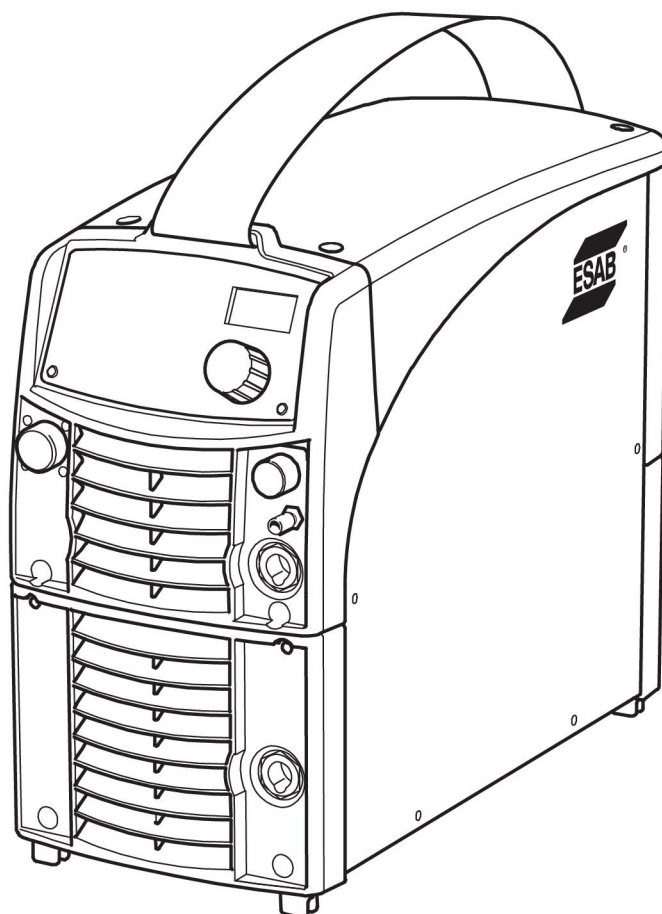

Caddy®

Tig 2200i AC/DC



Instruction manual

WELDING TECHNOLOGY
SUPPLIERS OF WELDING AND ENGINEERING EQUIPMENT

0460 225 301 GB 20180920



Ph: 09 274 1246

info@weldingtechnology.co.nz
www.weldingtechnology.co.nz

Valid for: serial no. 711-, 747-xxx-xxxx



EU DECLARATION OF CONFORMITY

According to
The Low Voltage Directive 2014/35/EU, entering into force 20 April 2016
The EMC Directive 2014/30/EU, entering into force 20 April 2016
The RoHS Directive 2011/65/EU, entering into force 2 January 2013

Type of equipment
Welding Power Source

Type designation
Tig 2200i AC/DC from serial number 711-xxx-xxxx (2017 w11)

Brand name or trade mark
ESAB

Manufacturer or his authorised representative established within the EEA
Name, address, and telephone No:
ESAB AB
Lindholmsallén 9, Box 8004, SE-402 77 Göteborg, Sweden
Phone: +46 31 50 90 00, Fax: +46 31 50 92 22

The following harmonised standard in force within the EEA has been used in the design:
EN 60974-1:2012, Arc Welding Equipment – Part 1: Welding power sources
EN 60974-3:2014, Arc Welding Equipment – Part 3: Arc striking and stabilizing devices
EN 60974-10:2014/A1:2015, Arc Welding Equipment – Part 10: Electromagnetic compatibility (EMC) requirements

Additional Information:
Restrictive use, Class A equipment, intended for use in location other than residential

By signing this document, the undersigned declares as manufacturer, or the manufacturer's authorised representative established within the EEA, that the equipment in question complies with the safety requirements stated above.

Date

Signature

Position

Gothenburg
2017-09-20

Stephen Argo

Global Director Equipment

CE 2017

WELDING TECHNOLOGY
SUPPLIERS OF WELDING AND ENGINEERING EQUIPMENT



Ph: 09 274 1246
info@weldingtechnology.co.nz
www.weldingtechnology.co.nz

TABLE OF CONTENTS

1	SAFETY	4
1.1	Meaning of symbols	4
1.2	Safety precautions	4
2	INTRODUCTION	7
2.1	Equipment	7
2.2	Control panels	7
3	TECHNICAL DATA	8
4	INSTALLATION	10
4.1	Lifting instructions	10
4.2	Location	10
4.3	Mains power supply	10
5	OPERATION	12
5.1	Connections and control devices	13
5.2	Key to symbols	13
5.3	Connection to cooling unit	14
5.4	Turning on the power source	14
6	MAINTENANCE	15
6.1	Inspection and cleaning	15
7	TROUBLESHOOTING	16
8	ORDERING SPARE PARTS	17
	ASSEMBLY INSTRUCTIONS	18
	DIAGRAM	19
	ORDERING NUMBERS	21
	ACCESSORIES	22

WELDING TECHNOLOGY
SUPPLIERS OF WELDING AND ENGINEERING EQUIPMENT



1 SAFETY

1.1 Meaning of symbols

As used throughout this manual: Means Attention! Be Alert!



DANGER!

Means immediate hazards which, if not avoided, will result in immediate, serious personal injury or loss of life.



WARNING!

Means potential hazards which could result in personal injury or loss of life.



CAUTION!

Means hazards which could result in minor personal injury.



WARNING!

Before use, read and understand the instruction manual and follow all labels, employer's safety practices and Safety Data Sheets (SDSs).



1.2 Safety precautions

Users of ESAB equipment have the ultimate responsibility for ensuring that anyone who works on or near the equipment observes all the relevant safety precautions. Safety precautions must meet the requirements that apply to this type of equipment. The following recommendations should be observed in addition to the standard regulations that apply to the workplace.

All work must be carried out by trained personnel well-acquainted with the operation of the equipment. Incorrect operation of the equipment may lead to hazardous situations which can result in injury to the operator and damage to the equipment.

1. Anyone who uses the equipment must be familiar with:
 - its operation
 - location of emergency stops
 - its function
 - relevant safety precautions
 - welding and cutting or other applicable operation of the equipment
2. The operator must ensure that:
 - no unauthorised person is stationed within the working area of the equipment when it is started up
 - no-one is unprotected when the arc is struck or work is started with the equipment
3. The workplace must:
 - be suitable for the purpose
 - be free from drafts

WELDING TECHNOLOGY
SUPPLIERS OF WELDING AND ENGINEERING EQUIPMENT



Ph: 09 274 1246
info@weldingtechnology.co.nz
www.weldingtechnology.co.nz

4. Personal safety equipment:
 - Always wear recommended personal safety equipment, such as safety glasses, flame-proof clothing, safety gloves
 - Do not wear loose-fitting items, such as scarves, bracelets, rings, etc., which could become trapped or cause burns
5. General precautions:
 - Make sure the return cable is connected securely
 - Work on high voltage equipment **may only be carried out by a qualified electrician**
 - Appropriate fire extinguishing equipment must be clearly marked and close at hand
 - Lubrication and maintenance must **not** be carried out on the equipment during operation



WARNING!

Arc welding and cutting can be injurious to yourself and others. Take precautions when welding and cutting.



ELECTRIC SHOCK - Can kill

- Install and ground the unit in accordance with instruction manual.
- Do not touch live electrical parts or electrodes with bare skin, wet gloves or wet clothing.
- Insulate yourself from work and ground.
- Ensure your working position is safe



ELECTRIC AND MAGNETIC FIELDS - Can be dangerous to health

- Welders having pacemakers should consult their physician before welding. EMF may interfere with some pacemakers.
- Exposure to EMF may have other health effects which are unknown.
- Welders should use the following procedures to minimize exposure to EMF:
 - Route the electrode and work cables together on the same side of your body. Secure them with tape when possible. Do not place your body between the torch and work cables. Never coil the torch or work cable around your body. Keep welding power source and cables as far away from your body as possible.
 - Connect the work cable to the workpiece as close as possible to the area being welded.



FUMES AND GASES - Can be dangerous to health

- Keep your head out of the fumes.
- Use ventilation, extraction at the arc, or both, to take fumes and gases away from your breathing zone and the general area.



ARC RAYS - Can injure eyes and burn skin

- Protect your eyes and body. Use the correct welding screen and filter lens and wear protective clothing.
- Protect bystanders with suitable screens or curtains.



NOISE - Excessive noise can damage hearing

Protect your ears. Use earmuffs or other hearing protection.

WELDING TECHNOLOGY
SUPPLIERS OF WELDING AND ENGINEERING EQUIPMENT



Ph: 09 274 1246

info@weldingtechnology.co.nz

www.weldingtechnology.co.nz

MOVING PARTS - Can cause injuries



- Keep all doors, panels and covers closed and securely in place. Have only qualified people remove covers for maintenance and troubleshooting as necessary. Reinstall panels or covers and close doors when service is finished and before starting engine.



- Stop engine before installing or connecting unit.
- Keep hands, hair, loose clothing and tools away from moving parts.

FIRE HAZARD



- Sparks (spatter) can cause fire. Make sure that there are no inflammable materials nearby.
- Do not use on closed containers.

MALFUNCTION - Call for expert assistance in the event of malfunction.

PROTECT YOURSELF AND OTHERS!



CAUTION!

This product is solely intended for arc welding.



WARNING!

Do not use the power source for thawing frozen pipes.



CAUTION!

Class A equipment is not intended for use in residential locations where the electrical power is provided by the public low-voltage supply system. There may be potential difficulties in ensuring electromagnetic compatibility of class A equipment in those locations, due to conducted as well as radiated disturbances.

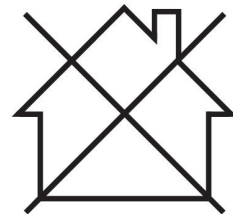

NOTE!

Dispose of electronic equipment at the recycling facility!

In observance of European Directive 2012/19/EC on Waste Electrical and Electronic Equipment and its implementation in accordance with national law, electrical and/or electronic equipment that has reached the end of its life must be disposed of at a recycling facility.

As the person responsible for the equipment, it is your responsibility to obtain information on approved collection stations.

For further information contact the nearest ESAB dealer.



ESAB has an assortment of welding accessories and personal protection equipment for purchase. For ordering information contact your local ESAB dealer or visit us on our website.

WELDING TECHNOLOGY
SUPPLIERS OF WELDING AND ENGINEERING EQUIPMENT



Ph: 09 274 1246
info@weldingtechnology.co.nz
www.weldingtechnology.co.nz

2 INTRODUCTION

The Tig 2200i AC/DC is a TIG welding power source, which can also be used for MMA welding. It can be used with alternating current (AC) or direct current (DC).

ESAB accessories for the product can be found in the "ACCESSORIES" chapter of this manual.

2.1 Equipment

The power source is supplied with a 5 m return cable, 3 m mains cable, carrying strap, cable holder, shaft belt, instruction manual for power source and control panel.

2.2 Control panels

- TA33 AC/DC

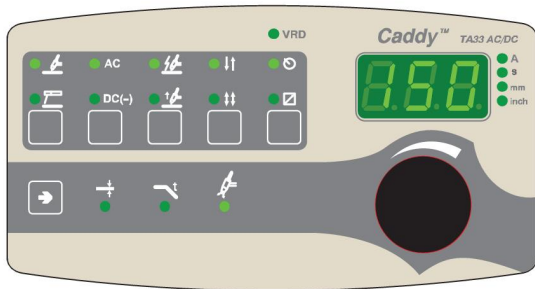

- TA34 AC/DC

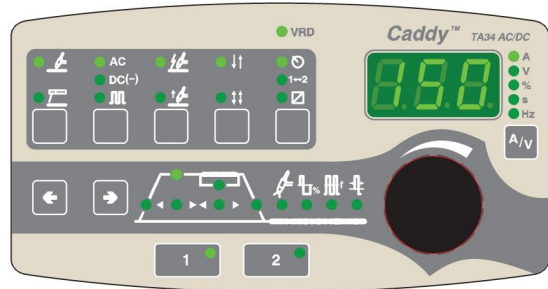

See the separate instruction manual for a detailed description of the control panels.

Instruction manuals in other languages can be downloaded from the Internet: www.esab.com



3 TECHNICAL DATA

Tig 2200i AC/DC, From serial no. 747-xxx-xxxx	
Mains voltage	230V, 10%, 1~ 50/60 Hz
Primary current I_{max}:	
MMA	25 A
TIG	28 A
No-load power (idle state)	41 W
Setting range:	
MMA	4 A/20 V–160 A/26.4 V
TIG, AC* / DC	3 A/10 V–220 A/18.8 V
Values of the conventional load:	
TIG (duty cycle at 40 °C/104 °F ambient temperature):	
20%	220 A / 18.8 V
60%	150 A / 16.0 V
100%	140 A / 15.6 V
MMA (duty cycle at 40 °C/104 °F ambient temperature):	
30%	160 A / 26.4 V
60%	120 A / 24.8 V
100%	110 A / 24.4 V
Power factor at maximum current (I_2):	
MMA	0.99
TIG	0.99
Efficiency at maximum current (I_2):	
MMA	73 %
TIG	65 %
Apparent power at max current (I_2)	6.4 kVA
Active power at max current (I_2)	6.3 KW
U_0 No-load voltage	58 V
U_r No-load voltage with VRD	25 V
U_{pk} (with arc ignition unit, Tig)	10.7 kV
Working temperature	-10 to +40 °C (+14 to +104 °F)
Continual sound pressure at no-load	< 70 dB(A)
Dimensions l×w×h	418×188×345 mm (16.46×7.40×13.58 in.)
Dimensions l×w×h with cooler	418×188×496 mm (16.46×7.40×19.53 in.)
Weight	15.7 kg (34.61 lbs)
Weight with cooler	22.1 kg (48.72 lbs)
Isolation class transformer	H
Enclosure class	IP23



Ph: 09 274 1246

info@weldingtechnology.co.nz

www.weldingtechnology.co.nz

Tig 2200i AC/DC, From serial no. 747-xxx-xxxx	
Application class	S
Restrictive use	Class A

*) The minimum current during AC welding depends on the alloy used for the aluminium plates and their surface cleanliness.

Duty cycle

The duty cycle refers to the time as a percentage of a ten-minute period that you can weld or cut at a certain load without overloading. The duty cycle is valid for 40 °C / 104 °F, or below.

Enclosure class

The **IP** code indicates the enclosure class, i.e. the degree of protection against penetration by solid objects or water.

Equipment marked **IP23** is intended for indoor and outdoor use.

Application class

The symbol **S** indicates that the power source is designed for use in areas with increased electrical hazard.

WELDING TECHNOLOGY
SUPPLIERS OF WELDING AND ENGINEERING EQUIPMENT



Ph: 09 274 1246
info@weldingtechnology.co.nz
www.weldingtechnology.co.nz

4 INSTALLATION

The installation must be carried out by a professional.



CAUTION!

This product is intended for industrial use. In a domestic environment this product may cause radio interference. It is the user's responsibility to take adequate precautions.

4.1 Lifting instructions

Install the carrying strap as illustrated and lift the power source by the strap.

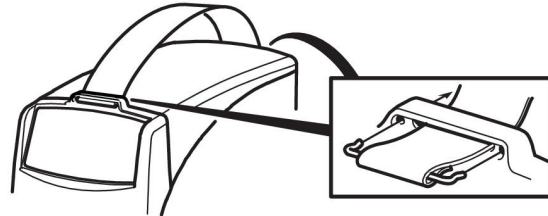

4.2 Location

Position the welding power source such that its cooling air inlets and outlets are not obstructed.

4.3 Mains power supply



NOTE!

Mains supply requirements

This equipment complies with IEC 61000-3-12 provided that the short-circuit power is greater than or equal to S_{scmin} at the interface point between the user's supply and the public system. It is the responsibility of the installer or user of the equipment to ensure, by consultation with the distribution network operator if necessary, that the equipment is connected only to a supply with a short-circuit power greater than or equal to S_{scmin} . Refer to the technical data in the TECHNICAL DATA chapter.

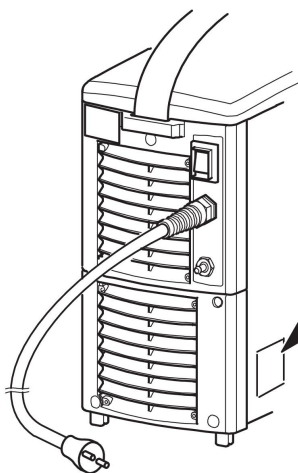

Check that the welding power source is connected to the correct mains power supply voltage, and that it is protected by the correct fuse size.

A protective earth connection must be made in accordance with regulations.

Rating plate with supply connection data

WELDING TECHNOLOGY
SUPPLIERS OF WELDING AND ENGINEERING EQUIPMENT



Ph: 09 274 1246
info@weldingtechnology.co.nz
www.weldingtechnology.co.nz

Recommended fuse sizes and minimum cable areas

Tig 2200i AC/DC		
Mains voltage		230 V \pm 10%, 1~ 50/60 Hz
Mains cable area		3 \times 2.5 mm ²
Primary current I _{max}		28 A
Phase current I _{1eff}		15 A
Fuse	Anti-surge	16 A
	Type C MCB	16 A

**NOTE!**

The mains cable areas and fuse sizes as shown above are in accordance with Swedish regulations. For other regions, supply cables must be suitable for the application and meet local and national regulations.



5 OPERATION

General safety regulations for handling the equipment can be found in the "SAFETY" chapter of this manual. Read it through before you start using the equipment!

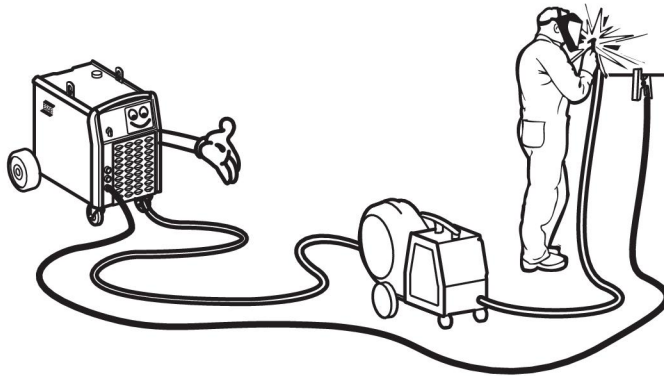
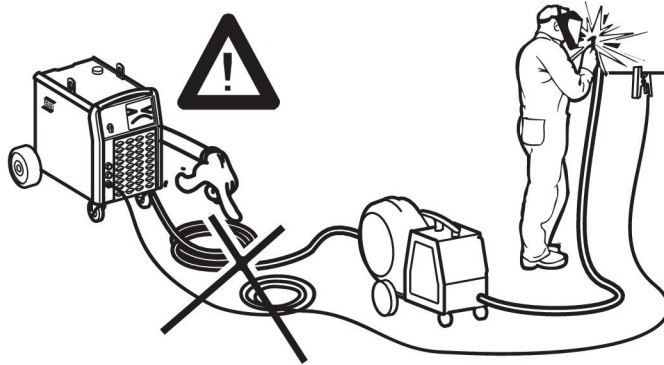

WELDING TECHNOLOGY
SUPPLIERS OF WELDING AND ENGINEERING EQUIPMENT



Ph: 09 274 1246
info@weldingtechnology.co.nz
www.weldingtechnology.co.nz

5.1 Connections and control devices

- | | | | |
|---|---|---|------------------------------|
| 1 | Connection for remote control unit | 6 | Connection for return cable |
| 2 | Control panel (see separate instruction manual) | 7 | Mains switch |
| 3 | Connection for torch | 8 | Mains cable |
| 4 | Connection for gas to the torch | 9 | Connection for shielding gas |
| 5 | Connection for welding cable or torch | | |

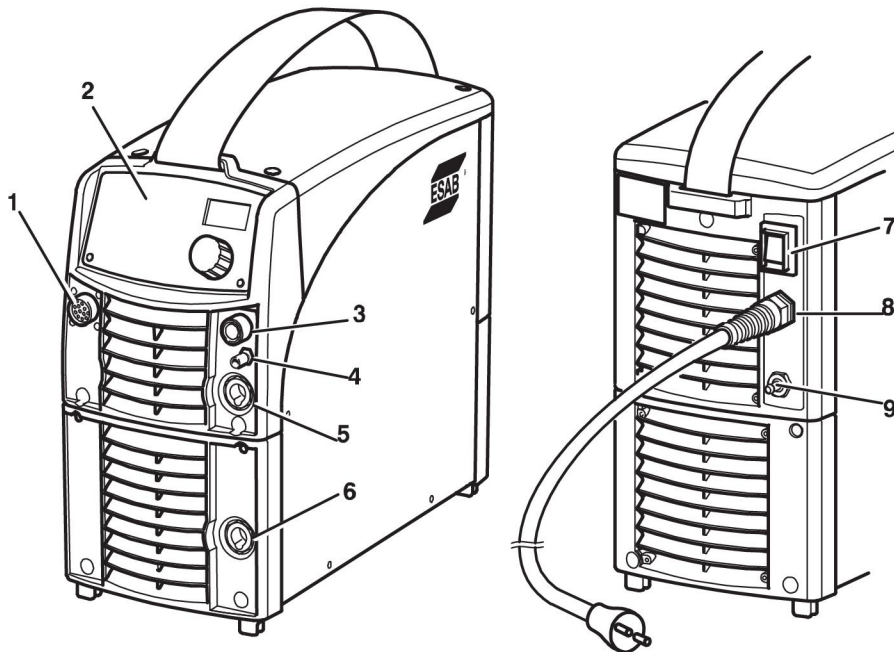

5.2 Key to symbols



MMA



TIG



Return clamp

WELDING TECHNOLOGY
SUPPLIERS OF WELDING AND ENGINEERING EQUIPMENT



Ph: 09 274 1246
info@weldingtechnology.co.nz
www.weldingtechnology.co.nz

5.3 Connection to cooling unit

Only those persons who have appropriate electrical knowledge (authorised personnel) may remove the safety plates to connect or carry out service, maintenance or repair work on welding equipment.

See installation instructions in chapter "INSTALLATION".



NOTE!

Coolant must be topped up if connecting a welding torch or connection cables that are 4 meters in length or longer.

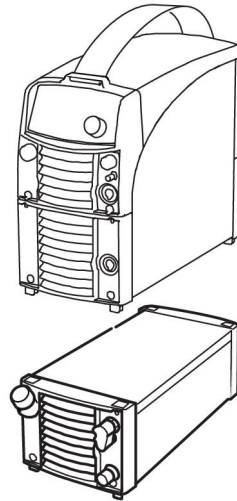

5.4 Turning on the power source

Turn on the mains power by turning the mains switch to the "1" position.

Turn the unit off by turning the switch to the "0" position.

Whether the mains power supply is interrupted or the power unit is switched off in the normal manner, welding data will be stored so that it is available next time the unit is started.



6 MAINTENANCE



NOTE!

Regular maintenance is important for safe and reliable operation.

Only those persons who have appropriate electrical knowledge (authorised personnel) may remove the safety plates to connect or carry out service, maintenance or repair work on welding equipment.



CAUTION!

All warranty undertakings from the supplier cease to apply if the customer attempts any work to rectify any faults in the product during the warranty period.

6.1 Inspection and cleaning

Power source

Check regularly that the welding power source is not clogged with dirt

How often and which cleaning methods apply depend on: the welding process, arc times, placement, and the surrounding environment. It is normally sufficient to blow down the power source with dry compressed air (reduced pressure) once a year.

Clogged or blocked air inlets and outlets otherwise result in overheating.

Welding torch

- The wear parts of the welding torch should be cleaned and replaced at regular intervals in order to achieve trouble-free wire feed. Blow the wire guide clean regularly and clean the contact tip.



7 TROUBLESHOOTING

Try these recommended checks and inspections before sending for an authorised service technician.

Type of fault	Corrective action
No arc.	<ul style="list-style-type: none"> • Check that the mains power supply switch is turned on. • Check that the welding current supply and return cables are correctly connected. • Check that the correct current value is set. • Check the mains power supply.
The welding current is interrupted during welding.	<ul style="list-style-type: none"> • Check to see whether the thermal cut-outs have tripped. • Check the mains power supply fuses.
The thermal cut-out trips frequently.	<ul style="list-style-type: none"> • Make sure that you are not exceeding the rated data for the welding power source (i.e. that the unit is not being overloaded).
Poor welding performance.	<ul style="list-style-type: none"> • Check that the welding current supply and return cables are correctly connected. • Check that the correct current value is set. • Check that the correct electrodes are being used. • Check the gas flow.



8 ORDERING SPARE PARTS



CAUTION!

Repair and electrical work should be performed by an authorised ESAB service technician. Use only ESAB original spare and wear parts.

Tig 2200i AC/DC is designed and tested in accordance with the international and European standards **IEC/EN 60974-1**, **60974-3** and **IEC/EN 60974-10 Class A**. It is the obligation of the service unit which has carried out the service or repair work to make sure that the product still conforms to the mentioned standards.

Spare parts and wear parts can be ordered through your nearest ESAB dealer, see esab.com. When ordering, please state product type, serial number, designation and spare part number in accordance with the spare parts list. This facilitates dispatch and ensures correct delivery.

WELDING TECHNOLOGY
SUPPLIERS OF WELDING AND ENGINEERING EQUIPMENT



Ph: 09 274 1246
info@weldingtechnology.co.nz
www.weldingtechnology.co.nz

ASSEMBLY INSTRUCTIONS

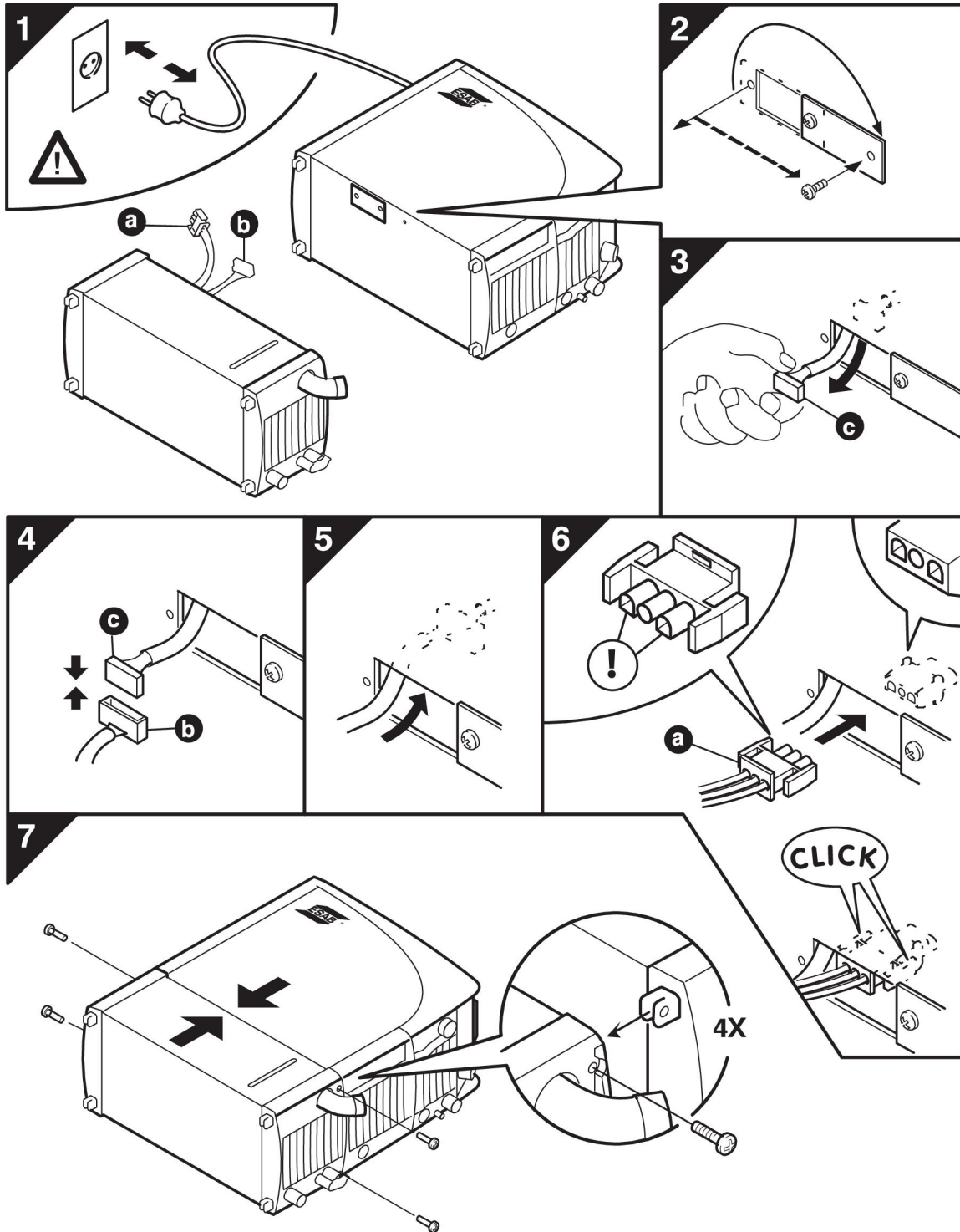

WELDING TECHNOLOGY
SUPPLIERS OF WELDING AND ENGINEERING EQUIPMENT



Ph: 09 274 1246
info@weldingtechnology.co.nz
www.weldingtechnology.co.nz

DIAGRAM

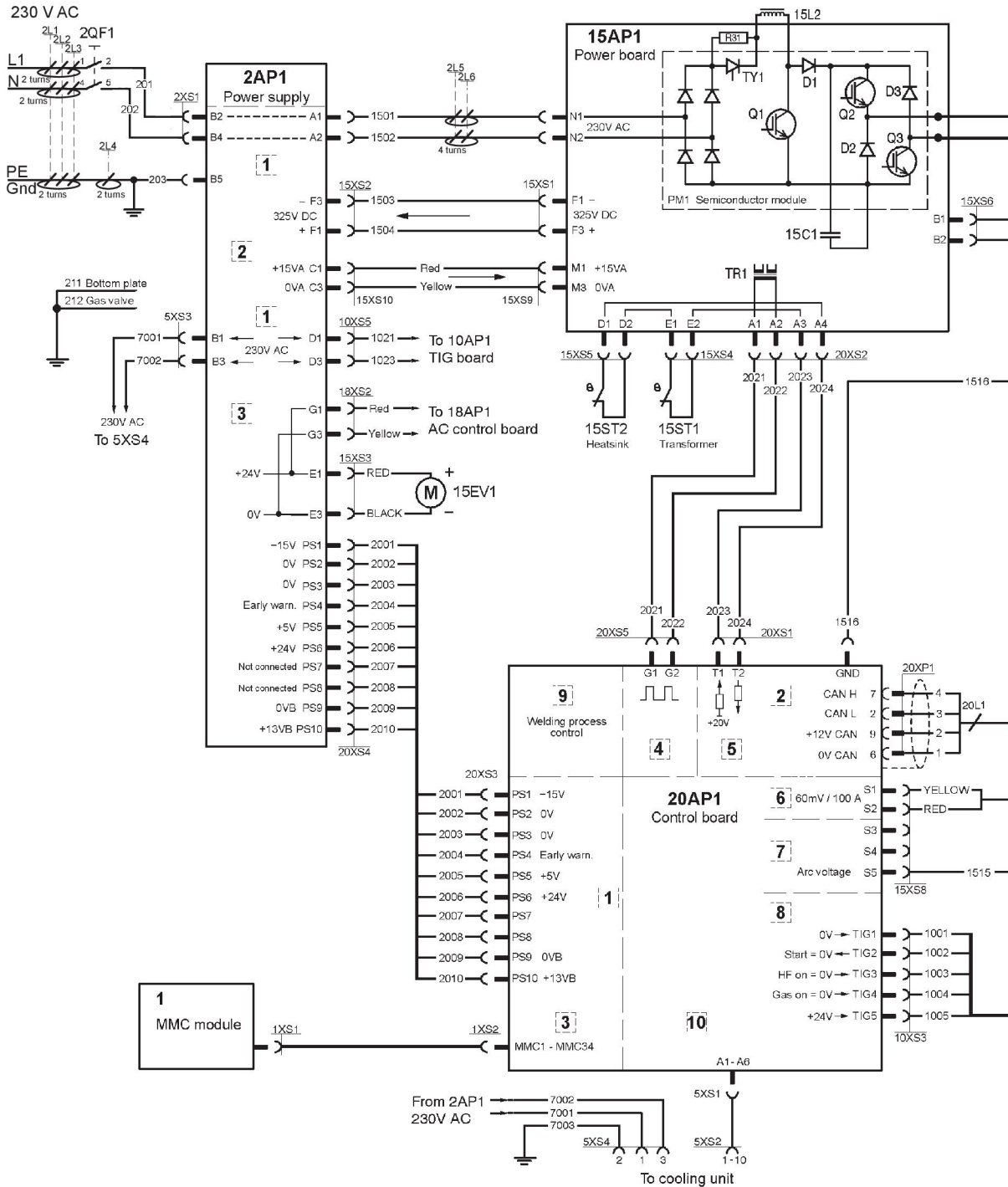

WELDING TECHNOLOGY
SUPPLIERS OF WELDING AND ENGINEERING EQUIPMENT



Ph: 09 274 1246

info@weldingtechnology.co.nz

www.weldingtechnology.co.nz

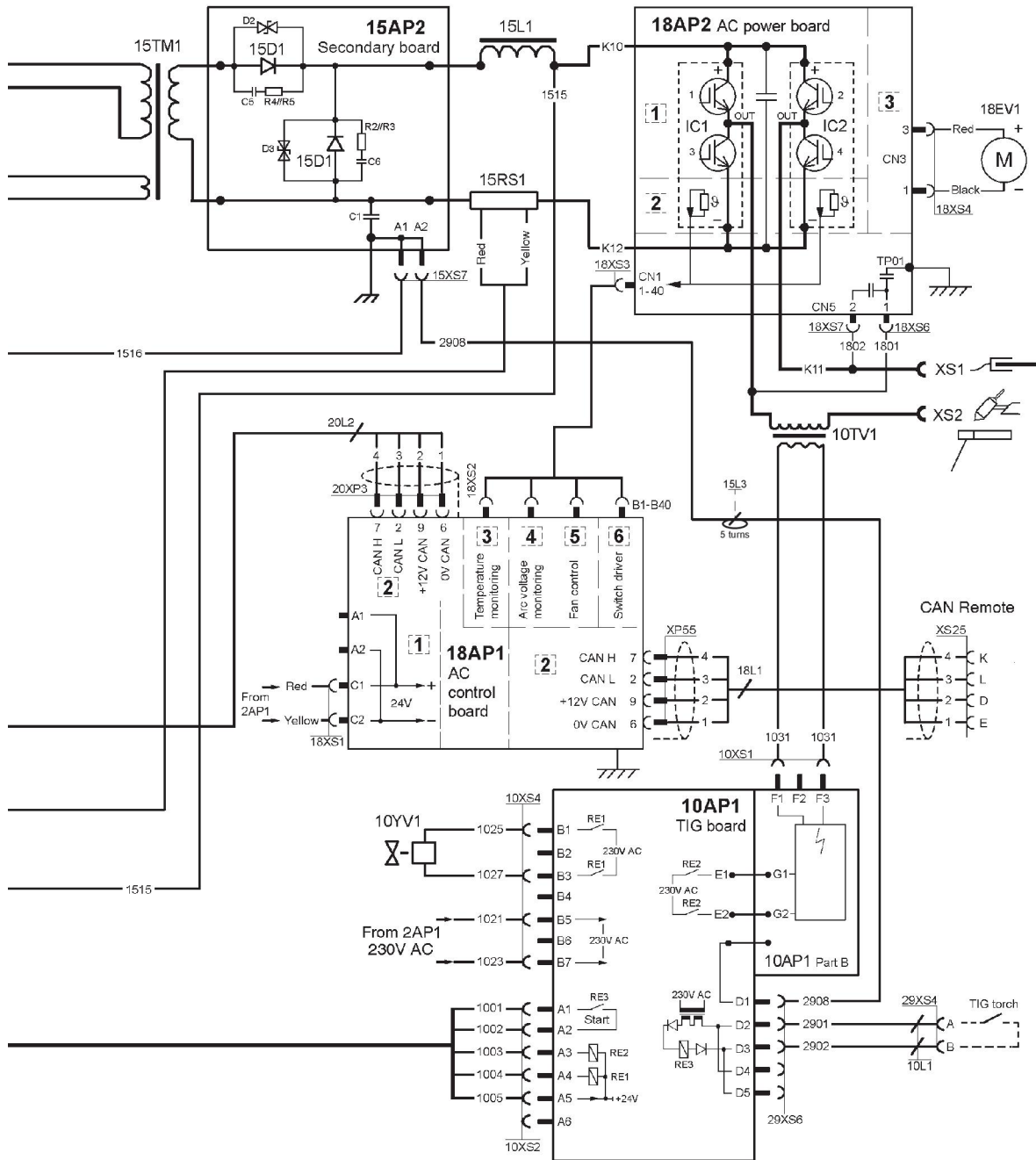

WELDING TECHNOLOGY
SUPPLIERS OF WELDING AND ENGINEERING EQUIPMENT



Ph: 09 274 1246
info@weldingtechnology.co.nz
www.weldingtechnology.co.nz

ORDERING NUMBERS

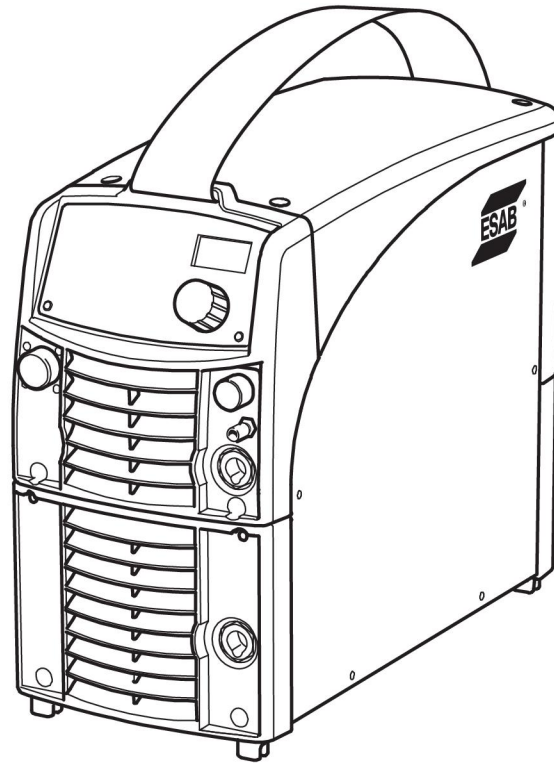

Ordering no.	Denomination	Type
0460 150 881	Welding power source	Caddy® Tig 2200i, AC/DC, TA33 AC/DC
0460 150 880	Welding power source	Caddy® Tig 2200i, AC/DC, TA34 AC/DC
0460 150 882	Welding power source	Caddy® Tig 2200i, AC/DC, TA33 AC/DC, MMA cable kit complete and Tig torch TXH201 4 m
0460 150 883	Welding power source	Caddy® Tig 2200i, AC/DC, TA34 AC/DC, MMA cable kit complete and Tig torch TXH201 4 m
0460 150 884	Welding power source	Caddy® Tig 2200i, AC/DC, TA34 AC/DC, MMA cable kit complete and Tig torch TXH251 4 m, Water cooler CoolMini, 2-wheel trolley

Filename	Denomination	Product
0459 839 013	Spare parts list	Welding power source, Tig 2200i AC/DC
0460 226	Instruction manual	Control panel, Caddy® TA33 AC/DC
0460 227	Instruction manual	Control panel, Caddy® TA34 AC/DC

Instruction manuals and the spare parts list are available on the Internet at: www.esab.com

WELDING TECHNOLOGY
SUPPLIERS OF WELDING AND ENGINEERING EQUIPMENT



Ph: 09 274 1246
info@weldingtechnology.co.nz
www.weldingtechnology.co.nz

ACCESSORIES





0459 491 910	Remote control adapter RA12 12 pole For analogue remote controls to CAN based equipment.	
0459 491 880	Remote control unit MTA1 CAN MIG/MAG: wire feed speed and voltage MMA: current and arc force TIG: current, pulse and background current	
0459 491 882	Remote control unit M1 10Prog CAN Choice of one of 10 programs MIG/MAG: voltage deviation TIG and MMA: current deviation	
0459 491 883	Remote control unit AT1 CAN MMA and TIG: current	
0459 491 884	Remote control unit AT1 CF CAN MMA and TIG: rough and fine setting of current.	
0700 006 884 0700 006 885	Welding cable kit Return cable kit	
0459 544 880 0459 554 881 0459 554 882 0459 554 883 0459 554 884	Remote cable CAN 4 pole - 12 pole 5 m 10 m 15 m 25 m 0.25 m	

WELDING TECHNOLOGY
SUPPLIERS OF WELDING AND ENGINEERING EQUIPMENT

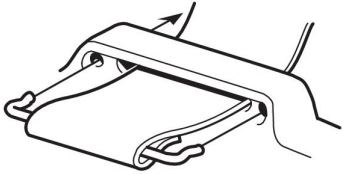
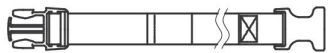

Ph: 09 274 1246
info@weldingtechnology.co.nz
www.weldingtechnology.co.nz

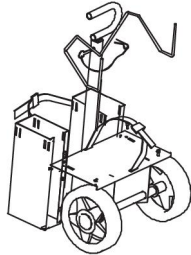
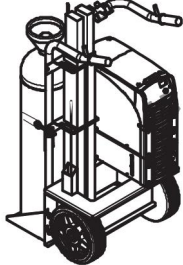
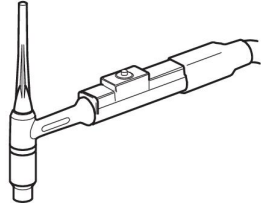
ACCESSORIES

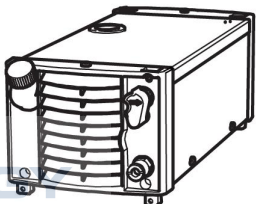
0460 265 001	Strap	
0460 265 002	Cable holder	
0460 265 003	Shoulder holder	
0459 366 885	Trolley for 5-10 litre gasbottle	
0460 330 880	Trolley for 20-50 litre gasbottle	
0700 300 552 0700 300 561	Tig torch TXH 201 4 m Tig torch TXH 251w 4 m	
0460 315 880	Foot pedal TI Foot CAN	
0460 144 880	Cooling unit CoolMini	

WELDING TECHNOLOGY
SUPPLIERS OF WELDING AND ENGINEERING EQUIPMENT



Ph: 09 274 1246
info@weldingtechnology.co.nz
www.weldingtechnology.co.nz



A WORLD OF PRODUCTS AND SOLUTIONS.



For contact information visit esab.com

ESAB AB, Lindholmsallén 9, Box 8004, 402 77 Gothenburg, Sweden, Phone +46 (0) 31 50 90 00

<http://manuals.esab.com>



WELDING TECHNOLOGY
SUPPLIERS OF WELDING AND ENGINEERING EQUIPMENT



Ph: 09 274 1246

info@weldingtechnology.co.nz
www.weldingtechnology.co.nz