

PAPR HELMET - P3

Powered Air Purifying Respirator | XA-PAPR-P3



Please read and understand this instruction manual carefully
before the installation and operation of this equipment.

© Xcel-Arc 2024

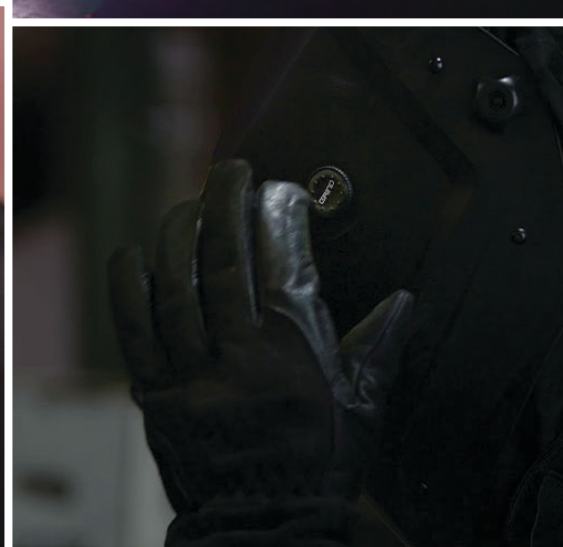

CONTENTS



SAFETY.....	4
INTRODUCTION.....	7
APPROVALS.....	7
USAGE.....	7
HELMET FEATURES.....	8
OPERATING INSTRUCTIONS.....	9
FILTER DISPLAY ICONS.....	9
UNPACKING/ASSEMBLY.....	11
FILTER REPLACEMENT.....	11
INSTALLING THE BATTERY/CHARGING.....	12
INSTALLING THE RESPIRATORY SYSTEM ON THE BELT.....	14
CONNECTING THE TUBE.....	15
ADJUST AIRFLOW RATE.....	15
AIR FLOW TEST.....	16
AIR FLOW ALARM TEST.....	17
FITTING.....	18
LCD AND OPERATION.....	19
OPERATION.....	20
PAPR WELDING HELMET PARTS LIST.....	21
REPLACEMENT.....	23
MAINTENANCE & STORAGE.....	23
PAPR UNIT TROUBLESHOOTING.....	24
HELMET TROUBLESHOOTING.....	25
RECOMMENDED SHADE SETTINGS.....	25
SPECIFICATION.....	26
MARKING EXPLANATION.....	26
WARRANTY.....	27

SAFETY

Welding and cutting equipment can be dangerous to both the operator and people in or near the surrounding working area, if the equipment is not correctly operated. Equipment must only be used under the strict and comprehensive observance of all relevant safety regulations.

Read and understand this instruction manual carefully before the installation and operation of this equipment.

Machine Operating Safety

- Do not switch the function modes while the machine is operating. Switching of the function modes during welding can damage the machine. Damage caused in this manner will not be covered under warranty.
- Disconnect the electrode-holder cable from the machine before switching on the machine, to avoid arcing should the electrode be in contact with the work piece.
- Operators should be trained and or qualified.



Electric shock: It can kill. Touching live electrical parts can cause fatal shocks or severe burns. The electrode and work circuit is electrically live whenever the output is on. The input power circuit and internal machine circuits are also live when power is on. In MIG/MAG welding, the wire, drive rollers, wire feed housing, and all metal parts touching the welding wire are electrically live. Incorrectly installed or improperly grounded equipment is dangerous.

- Connect the primary input cable according to Australian and New Zealand standards and regulations.
- Avoid all contact with live electrical parts of the welding/cutting circuit, electrodes and wires with bare hands.
- The operator must wear dry welding gloves while he/she performs the welding/cutting task.
- The operator should keep the work piece insulated from himself/herself.
- Keep cords dry, free of oil and grease, and protected from hot metal and sparks.
- Frequently inspect input power cable for wear and tear, replace the cable immediately if damaged, bare wiring is dangerous and can kill.
- Do not use damaged, under sized, or badly joined cables.
- Do not drape cables over your body.
- We recommend (RCD) safety switch is used with this equipment to detect any leakage of current to earth.



Fumes and gases are dangerous. Smoke and gas generated whilst welding or cutting can be harmful to people's health. Welding produces fumes and gases. Breathing these fumes and gases can be hazardous to your health.

Do not breathe the smoke and gas generated whilst welding or cutting, keep your head out of the fumes

- Keep the working area well ventilated, use fume extraction or ventilation to remove welding/cutting fumes and gases.
- In confined or heavy fume environments always wear an approved air-supplied respirator.
- Welding/cutting fumes and gases can displace air and lower the oxygen level causing injury or death. Be sure the breathing air is safe.
- Do not weld/cut in locations near de-greasing, cleaning, or spraying operations. The heat and rays of the arc can react with vapours to form highly toxic and irritating gases.
- Materials such as galvanized, lead, or cadmium plated steel, containing elements that can give off toxic fumes when welded/cut. Do not weld/cut these materials unless the area is very well ventilated, and or wearing an air supplied respirator.



Arc rays: harmful to people's eyes and skin. Arc rays from the welding/cutting process produce intense visible and invisible ultraviolet and infrared rays that can burn eyes and skin.

Always wear a welding helmet with correct shade of filter lens and suitable protective clothing including welding gloves whilst the welding/cutting operation is performed.

- Measures should be taken to protect people in or near the surrounding working area. Use protective screens or barriers to protect others from flash, glare and sparks; warn others not to watch the arc.



Fire hazard. Welding/cutting on closed containers, such as tanks, drums, or pipes, can cause them to explode. Flying sparks from the welding/cutting arc, hot work piece, and hot equipment can cause fires and burns. Accidental contact of electrode to metal objects can cause sparks, explosion, overheating, or fire. Check and be sure the area is safe before doing any welding/cutting.

- The welding/cutting sparks & spatter may cause fire, therefore remove any flammable materials well away from the working area. Cover flammable materials and containers with approved covers if unable to be moved from the welding/cutting area.
- Do not weld/cut on closed containers such as tanks, drums, or pipes, unless they are properly prepared according to the required Safety Standards to insure that flammable or toxic vapours and substances are totally removed, these can cause an explosion even though the vessel has been "cleaned". Vent hollow castings or containers before heating, cutting or welding. They may explode.
- Do not weld/cut where the atmosphere may contain flammable dust, gas, or liquid vapours (such as petrol)
- Have a fire extinguisher nearby and know how to use it. Be alert that welding/cutting sparks and hot materials from welding/cutting can easily go through small cracks and openings to adjacent areas. Be aware that welding/cutting on a ceiling, floor, bulkhead, or partition can cause fire on the hidden side.



Gas Cylinders. Shielding gas cylinders contain gas under high pressure. If damaged, a cylinder can explode. Because gas cylinders are normally part of the welding/cutting process, be sure to treat them carefully. CYLINDERS can explode if damaged.

- Protect gas cylinders from excessive heat, mechanical shocks, physical damage, slag, open flames, sparks, and arcs.
- Insure cylinders are held secure and upright to prevent tipping or falling over.
- Never allow the welding/cutting electrode or earth clamp to touch the gas cylinder, do not drape welding cables over the cylinder.
- Never weld/cut on a pressurised gas cylinder, it will explode and kill you.
- Open the cylinder valve slowly and turn your face away from the cylinder outlet valve and gas regulator.



Gas build up. The build up of gas can causes a toxic environment, deplete the oxygen content in the air resulting in death or injury. Many gases use in welding/cutting are invisible and odourless.

- Shut off shielding gas supply when not in use.
- Always ventilate confined spaces or use approved air-supplied respirator.



Electronic magnetic fields. MAGNETIC FIELDS can affect Implanted Medical Devices.

- Wearers of Pacemakers and other Implanted Medical Devices should keep away.
- Implanted Medical Device wearers should consult their doctor and the device manufacturer before going near any electric welding, cutting or heating operation.



Noise can damage hearing. Noise from some processes or equipment can damage hearing.

- Wear approved ear protection if noise level is high.



Hot parts. Items being welded/cut generate and hold high heat and can cause severe burns.

Do not touch hot parts with bare hands. Allow a cooling period before working on the welding/cutting gun. Use insulated welding gloves and clothing to handle hot parts and prevent burns.



WARNING: Contains button battery, hazardous if swallowed. Keep out of reach from children. Battery can cause severe or fatal injuries in 2 hours or less if it is swallowed or placed inside any part of the body. Medical attention should be sought immediately if it is suspected the battery has been swallowed or placed inside any part of the body.

SAFETY

Please read and understand all instructions before using.

- Be sure that the dark shade of the lens in the welding helmet is on the correct shade number for your application.
- The helmet and lenses are not suitable for "overhead" welding application, laser welding, or laser cutting applications.
- Welding helmets are designed to protect the eyes and face from sparks, spatter, and harmful radiation under normal welding conditions.
- This helmet will not protect against explosive devices or corrosive liquids. Machine guards or eye splash protection must be used when these hazards are present.
- Impact resistant, primary eye protection, spectacles or goggles that meet current AS/NZS specifications, must be worn at all times when using this welding helmet.
- Avoid work positions that could expose unprotected areas of the body to sparks, spatter, direct and/or reflected radiation. Use appropriate protection if exposure cannot be avoided.
- Before each use, check that the protection plates are clean and that no dirt is covering the sensors on the front of the lens.
- Inspect all operating parts before each use for signs of wear or damage. Any scratched, cracked, or pitted parts should be replaced immediately.
- Do not make any modifications to either the welding lens or helmet, other than those specified in this manual. Do not use any replacement parts other than those specified in this manual. Unauthorised modifications and replacement parts will void the warranty and expose the user to the risk of personal injury.
- If this lens does not darken when striking arc, stop welding immediately and check the helmet is in Weld Mode and not Grind Mode. If the issue persists, contact your local Xcel-Arc Service Department.
- Do not immerse this lens in water.
- Do not use any solvents on any lens or helmet components.
- The recommended operating temperature range for this welding lens is -10°C to 65°C (14°F-149°F). Do not use this device beyond these temperature limits.
- Failure to follow these warnings and/or failure to follow all of the operating instructions could result in severe personal injury.

INTRODUCTION

PAPR-P3 Respiratory System is a combined face and breathing protection device for increased safety and comfort during welding. Please read these instructions carefully before unpacking. For proper use, see User Instructions or contact the manufacturers for help.

Address and telephone number information is printed at the back of this leaflet.

Your PAPR-P3 Air Powered Respirator system should include:

- Auto-darkening welding helmet
- PAPR blower unit with attached battery and filter
- Belt
- Battery charger
- Airflow indicator
- Instruction manual
- Carry bag

If any of the above components are not included in your kit, please contact the supplier immediately.



APPROVALS

The PAPR-P3 system complies with the requirements of Australian/New Zealand standard AS/NZS 1716:2012 as a PAPR-P3 device. All components used in PAPR-P3 Respiratory System must be "Xcel-Arc approved" manufacturer's parts, and must be used in accordance with the instructions in this manual.

NOTE: The approval is not valid if the product is incorrectly used together with non-approved parts or components.

NOTE: Only the PAPR-P3 particle filter, gas filter and pre-filter can be used together with this system. Filters from other manufacturers should under no circumstances be used.

USAGE

The PAPR-P3 Respiratory System is designed to provide a supply of filtered air via a breathing tube to a welding headpiece. The complete system is a breathing protection device complying with Australian/New Zealand standard AS/NZS 1716:2012, class P3. The equipment can be used in environment that requires a class P3 breathing protection device. It protects against particulate contamination.

LIMITATIONS TO USE

The PAPR-P3 Respiratory System must only be used with the PAPR-P3 unit switched on. If the equipment is used without the PAPR-P3 unit switched on, there is a risk of high concentration of CO₂ and the oxygen level in the helmet will fall, thus little or no protection is given in the power-off state and this is considered to be an abnormal situation. Do not remove the helmet or turn off the air filter unit until you have vacated the contaminated area. If you are not sure about the concentration of pollution, or about equipment performance, ask the industrial safety engineer. The manufacturer is not responsible for injury following incorrect use or incorrect choice of equipment.

- DO NOT use PAPR-P3 with the blower unit switched off.
- DO NOT use PAPR-P3 in an atmosphere that is immediately hazardous to user hygiene or health and or has oxygen content of less than 19.5% or contains unknown substances.
- DO NOT use PAPR-P3 in an explosive atmosphere.
- DO NOT use PAPR-P3 in confined spaces or areas of poor ventilation.
- DO NOT use PAPR-P3 in high winds.
- DO NOT alter or modify in any way.
- DO NOT touch any of the moving parts.
- DO NOT allow water or other liquids to enter the impeller chamber, the filter or battery compartment.
- DO NOT use the PAPR-P3 as head protection. THIS HEAD COVERING DOES NOT MEET THE REQUIREMENTS OF AS/NZS 1801. IF HEAD PROTECTION IS REQUIRED CONSULT YOUR SAFETY OFFICER
- The helmet and lenses are not suitable for "overhead" welding application, laser welding, or laser cutting applications.

PAPR WELDING HELMET

HELMET FEATURES

The PAPR Welding Helmet is equipped with an automatic darkening filter. The filter is transparent before welding so that the operator may observe the work surface clearly. When striking the arc, the filter darkens automatically immediately. When the arc goes out, the filter will become transparent again. The switching time from light to dark is 0.08 ms. The switching time from dark to light may be set up within 0.1-0.9 second.

The helmet is equipped with a continuous darkness-adjusting unit so that the operator may select an arbitrary dark shade number ranging from 5-9 or 9-13. The helmet also features 3 memory states to save desired settings.

The PAPR Welding Helmet gives the operator permanent complete protection against UV/IR, even in the transparent state. The UV/IR protection level is up to DIN15. The power is provided by solar cells and a replaceable battery.

The helmet is equipped with four photosensors to sense arc light. In addition, the helmet contains an outer protection shell made of high polymer materials. The plate is wear-resistant, thermostable, and has no dregs-sticking, giving a very long service life.

The PAPR Welding Helmet is a ELITEVISION™ welding helmet. With advanced ELITEVISION™ technology, the users can weld with improved clarity due to new Blue Optical Coating technology, grind with precision while in grind mode and finally see the job performance in the light state in the full spectrum of colours. There is now no need to remove the helmet to see clearly!



ELITEVISION™

LENS TECHNOLOGY

TECHNICAL DATA		TECHNICAL DATA	
SKU	PAPR-P3	ADF Model	XA-5122D(G)
Filter Dimensions	114 x 133 x 9.5 mm	Sensitivity Delay	Adjustable (1-5 for low-high)
View Size	100 x 83.4 mm	Power Supply	Solar Cells & CR2450 Replaceable Battery
Classification	1/1/1/1	Warranty	2 Years
Light State	4	Operating Temperature	-10°C to 65°C
Dark State	5-9 / 9-13	Storage Temperature	-20°C to 85°C
UV/IR Protection	DIN15	Shade Control	Yes
Time from Light to Dark	0.08ms	Grind Mode	Yes
Time from Dark to Light	0.1-0.9s	Standards	ANSI Z87.1 / DIN / CE / TUV

OPERATING INSTRUCTIONS

VARIABLE SHADE CONTROL

- If the Shade is in the range of **5-9**, press **WELD/GRIND** button repeatedly until both **Icon 2** and **Icon 4** appears on the screen. Then press **SHADE** button repeatedly until the desired Shade shown in **Icon 8**.
- If the Shade is in the range of **9-13**, press **WELD/GRIND** button repeatedly until both **Icon 2** and **Icon 5** appears on the screen. Then press **SHADE** button repeatedly until the desired Shade shown in **Icon 8**.

Note:

- Choose an optimum Shade number for the required welding process or application.
- If this lens does not darken when striking arc, stop welding immediately and check the helmet is in Weld Mode and not Grind Mode. If the issue persists, contact your local Xcel-Arc Service Department.

SENSITIVITY CONTROL

The responsiveness to different light levels in various welding processes can be adjusted in the range 1-5 (from low to high).

Press the **SENSITIVITY** button twice to start the setting, **Icon 6** will flash on the screen (from 1 to 5). Repeatedly press the **SENSITIVITY** button until the desired level shown in **Icon 6**.

- **Turn to 1 (low):** The photosensitivity changes to be lower.
 - Suitable for high amperage welding and welding in bright light conditions (lamp light or sunlight).
- **Turn to 5 (high):** The photosensitivity changes to be higher.
 - Suitable for low amperage welding and using in poor light conditions.
 - Suitable for use with steady arc process such as TIG welding.
 - Under normal use, a higher sensitivity setting is recommended.

DELAY CONTROL

The length of time delay for the ADF to return to the light state after welding can be adjusted in the range 1-5 (for 0.1-0.9s). The time delay is for protection of the welder's eyes from strong residual rays after welding.

Press the **DELAY** button twice to start the setting, **Icon 7** will flash on the screen (from 1 to 5). Repeatedly press the **DELAY** button until the desired length of time delay shown in **Icon 7**.

- **Turn to 1 (0.1s):** The time the ADF takes to lighten after welding becomes shorter. The shortest time is about 0.1s depending on the welding point temperature and shade setting. This setting is ideal for track welding or production welding with short welds.
- **Turn to 5 (0.9s):** The time the ADF takes to lighten after welding becomes longer. The longest time is about 0.9s depending on the welding point temperature and shade setting. This setting is ideal for welding at high amperage where there is an afterglow from the weld.

GRIND SELECTION



EXTERNAL GRIND BUTTON - With the external grind button you can keep the helmet on while you're grinding, no need to remove your safety gear or fiddle around with flip lens or hoods. Press and hold the **GRIND** button to activate the grind mode.

INTERNAL BUTTON - Press **WELD/GRIND** button repeatedly until **Icon 3** appears on the screen and the red light on the button flashes. Additionally, **Icon 8** will show shade 4.

Note: Do not weld in the Grind mode, the ADF will not darken.

FILTER DISPLAY ICONS

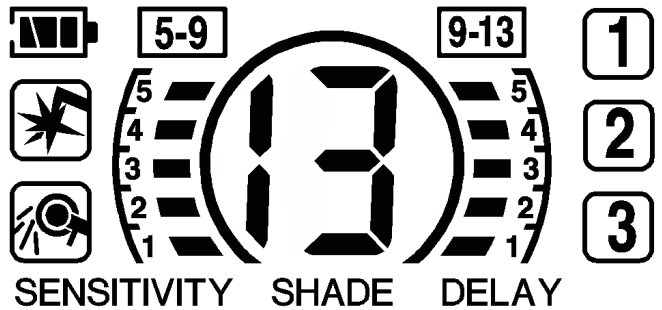

1. Battery Status	2. Welding Indication	3. Grinding Indication	4. Shade Range 5-9	5. Shade Range 9-13
6. Sensitivity indication: 1 (low) to 5 (high)	7. Delay indication: 1 (short 0.1s) to 5 (long 0.9s)	8. Shade reading	9. Memory selection	



Note: Buttons on the left of the screen need to be pressed twice to start any settings. Otherwise they will not operate.

PAPR WELDING HELMET

MEMORY SETTING

The three most frequently used settings can be stored and reactivated easily by using the **3 MEMORY** buttons on the right side of the screen.

Upon use of this helmet, the last ADF settings will be stored automatically (stored about 5 minutes after). The next time when you start to weld, the last settings will be automatically re-activated.

- If you want to store a complete welding setting, press and hold one of the memory buttons and release when the **Icon 9** stops flashing.
- To activate the stored memory, press the memory button.

Note: Only in welding mode you can activate the memory. Change to welding mode if you are currently using the grinding function.

HEADGEAR ADJUSTMENTS

The harness can be adjusted for better comfort during operation. The **Headband Adjustment Button** adjusts the size of the headband. The **Segmental Positioning Plate** adjusts the viewing angle. The **Headband Tightness Knob** adjusts the tightness of the headband.

BATTERY INDICATOR

Icon 1 indicates battery status. Replace the battery when it is low; otherwise, the ADF switching time will become slower, and shade accuracy will be compromised.

POWER SUPPLY AND REPLACING THE BATTERY

The power of the auto-darkening helmet is provided by solar cells and a CR2450 lithium battery. To change the battery, open the Battery holder at the side of the ADF and replace the battery.

ADDITIONAL INSTRUCTIONS

- Be sure that the helmet is used in the correct condition and according to the SAFETY content.
- There is a liquid crystal-valve in the filter, although it has inner and outer protection plate, it is important to avoid heavy knocks to the helmet.
- The outer protective shell of the helmet should be periodically inspected and cleaned. In the case of a break, crack, pitting or other damage, the helmet shell must be replaced.
- To operate more efficiently and safely, please select the correct dark shade number.
- The arc light must be visible completely by the sensor. If not, the filter will be transparent or unstable in darkness.
- Please use the automatic filter at a temperature between -10°C-65°C (14°F-149°F)
- Do not disassemble the filter. If any problems arise, please contact your local Xcel-Arc service department.

REPLACEABLE PARTS

- Outer Lens - XA-FCL133-114
- Inner Lens - XA-AS7-1-ICL
- Head Band Assembly - XA-P0201-P3
- Sweat Band - XA-SWB-PAPR-P3
- CR2450 Battery - XA-AS4-1-BAT
- 1.5x Magnification Lens - MWL4215
- 2.0x Magnification Lens - MWL4220

UNPACKING/ASSEMBLY

Check that correct number of components has been supplied, as in FIGURE 1.

Check that the apparatus is complete, undamaged and correctly assembled. Any damaged or defective parts must be replaced before use.

Figure 1



FILTER REPLACEMENT

If the filter is heavily loaded with particles or damaged, it should be replaced. Never attempt to clean the filter by any means, it can damage the filter media easily. The Pre-filter (if used) should be intact without any tears or cuts. Please replace the pre-filter once it's wet or heavily loaded with particulate..

1)



Remove the filter cover by pressing in the latch of the filter cover.

2)



The filter cover is released.

3)

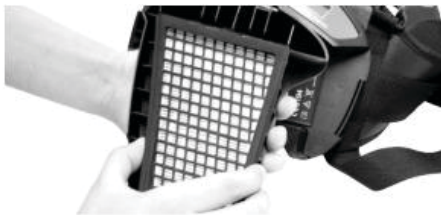

Remove the used filter by lifting it out from the filter cover.

4)



5)



Remove the pre-filter.

6)

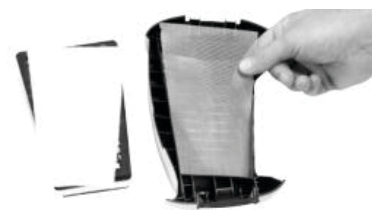

Clean the spark arrestor if necessary.

PAPR WELDING HELMET

INSTALLING THE BATTERY/CHARGING

1)



Slide the battery towards the back of the filtration unit.

2)



Make sure that the battery is locked in position.

3)



The battery can be charged on the filtration unit or separately.



The battery is partially charged when delivered. It must be charged at a 100% (4 bars) before the first use.

⚠ It is recommended to charge the batteries at a 100% before each use.



The charger must not be used for anything else than it was designed for. Do not charge the battery in a potentially explosive area. The charger must only be used indoors.

The charger regulates the charge automatically, once the battery is fully charged, it will maintain it at a 100% (floating charge).

The charge time is 3 to 4 hours.



The battery will discharge itself after long storage periods. Always charge the battery if the device was stored for more than 15 days. When the battery is new or has been stored for more than 3 months, charge it and discharge it at least twice in a row to reach the nominal / rated charge capacity.

Battery charge :

1. Connect the battery to the charger. The connector is above the battery.
2. Connect the charger to the mains.
3. The state of charge is displayed via a red LED on the mains charger.
4. Once the charge is finished, the floating charge becomes active: the red LED switches off and a green LED switches on.
5. Disconnect the charger from the mains (do not keep the charger plugged to the mains if it's not in use).



PAPR WELDING HELMET

INSTALLING THE RESPIRATORY SYSTEM ON THE BELT

1)



Remove the belt's release buckle.

2)



Remove the fastening belt from the waist connector's 2 belt loops.

3)



Make the fastening belt pass through the respiratory system's 2 belt loops.

4)



Position the Velcro® between the 2 loops.

5)



Flip the filtration system and attach the Velcro on the belt.

6)



Put the fastening belt back through the 2 belt loops.

7)



Put the buckle back.

8)



Attach the harness to the belt's 4 plastic rings.

MAKE SURE THE BELT IS SECURELY FASTENED.

CONNECTING THE TUBE

1)



Connect the air tube to the respiratory system and twist it clockwise to lock its position.

2)



Connect the other end of the tube to the headgear in the same way.

**CHECK THAT THE RESPIRATORY TUBE IS STRONGLY CONNECTED.
IF THE TUBE IS BROKEN, REPLACE IT.**

ADJUST AIRFLOW RATE

The airflow rate in the middle and both side of the airduct outlet can be adjusted by a switch assembled on airduct according to personal preference..

1)

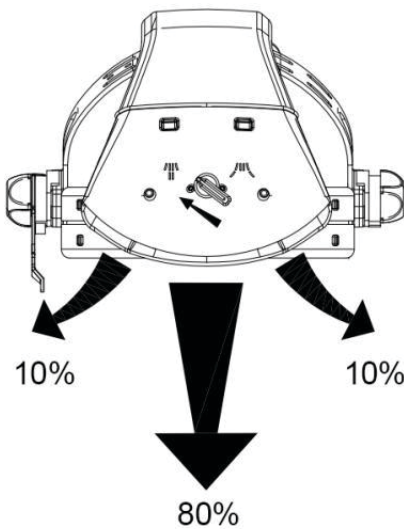

anticlockwise adjust the switch, airflow rate from middle outlet will be 80% and both side outlet will be 20%

2)

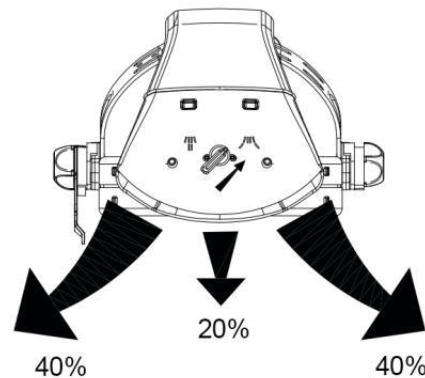

Clockwise adjust the switch, airflow rate from middle outlet will be 20% and both side outlet will be 80%



All components must be installed/ used in accordance with this manual if the equipment is to offer the specified protection. If any component is missing, or if anything is not clear, contact the supplier.

PAPR WELDING HELMET

AIR FLOW TEST

1)



Connect the breathing tube to the turbo unit and twist it clockwise to lock it.

2)



Insert the flowmeter at the tip of the tube.

3)



Press the ON button and maintain the tube in a vertical position at eyes' height.

4)



The air flow is sufficient if the marble reaches the minimum flow level O.



1. The airflow must be tested before using.

2. If the marble can't reach the minimum flow level, don't use the system.

Change the filter or the battery and retest the air flow.

AIR FLOW ALARM TEST



Remove the tube from the helmet and press the ON button.



Cover the air output with your hand and wait approximately 15 seconds.

IF THE ALARM DOES NOT WORK, PLEASE REPAIR OR CHANGE RESPIRATORY SYSTEM.

WARNING!

Leave the contaminated area immediately if:

1. Any part of the system becomes damaged.
2. Airflow into the helmet decreases or stops.
3. Breathing becomes difficult.
4. Dizziness or other distress occurs.
5. You taste or smell contaminants or an irritation occurs.
6. At very high work rates, the pressure in this PAPR device may become negative at peak inhalation flow.

PAPR WELDING HELMET

FITTING

1)

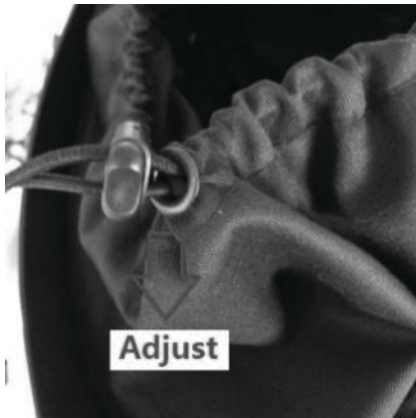

Adjust the tightness of the face seal and put on the head top.

2)

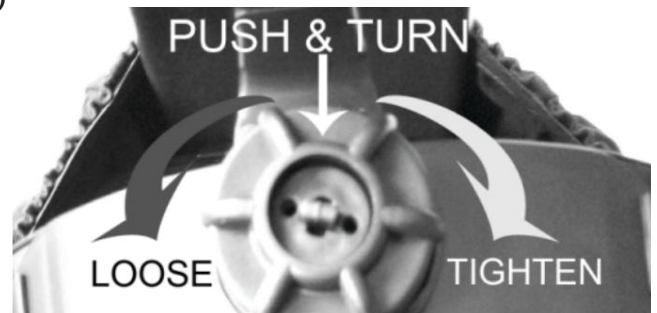

Adjust the headgear to suitable tightness

(push and turn left to loosen, turn right to tighten)

MAKE SURE THE FACE SEAL IS POSITIONED PROPERLY, OTHERWISE, YOU CAN'T GET SUFFICIENT SEALING NEEDED TO OFFER THE CORRECT PROTECTION FACTOR.

LCD AND OPERATION

LCD

There is a LCD display on PAPR-P3 unit to show the PAPR-P3 working condition

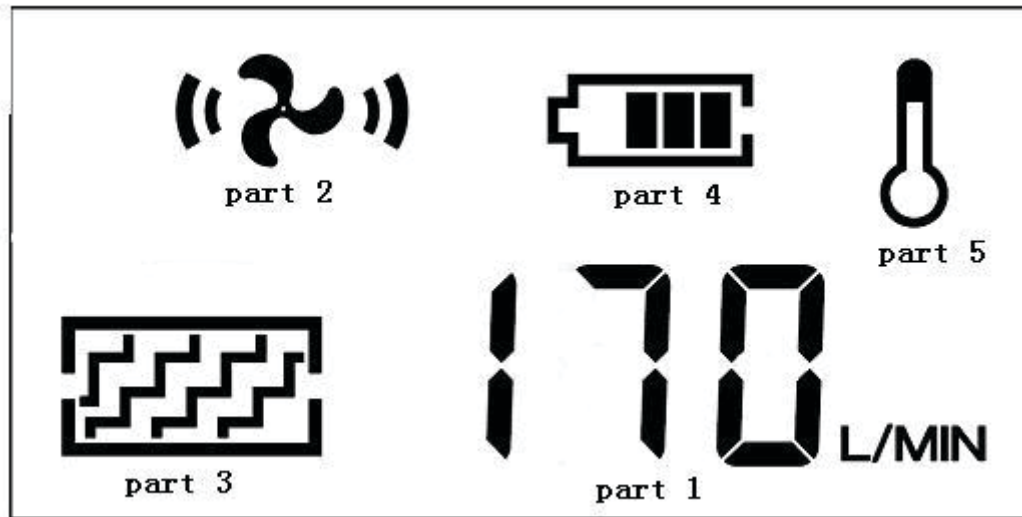

Part 1 shows the data of current air flow.

- **Part 2** shows the level of the airflow.
- **Part 3** shows the filter condition.
- **Part 4** shows the battery.
- **Part 5** shows the temperature of the battery.

Any of them will flash if PAPR-P3 malfunctions.

PAPR WELDING HELMET

OPERATION



Switch the device on by pressing the ON button once.



Press the ON button once again, the air flow is at level 1 (~170L/min).



Press the ON button once again, the air flow is at level 2 (~200L/min).



Press the ON button once again, the air flow is at level 3 (~230L/min).

Press the ON button once again, the air flow reverts to level 1 (~170L/min).



1. Respiratory system will turn off the turbo unit if long press the OFF button more than 3 seconds.
2. Respiratory system will cut off the entire circuit and switch to sleep mode if the turbo unit has turned off for more than 30 minutes. Pressing the ON button can activate the system.
3. The Respiratory system must be operated in the temperature range of -5°C to +55°C and relative humidity less than 90%RH.

REPLACEMENT

REPLACING THE FILTER

The installed filter has a limited service life based on working conditions. When the filter mark on the screen flashes and the alarm rings, filter should be replaced. If the filter is installed but unused, it has a limited service life of 5 years.

1. Remove the filter cover by pressing in the latch of the filter cover
2. Remove the used filter by lifting it out from the filter cover.
3. Install a new filter in the filter cover. (NOTE: Unauthorized filter will void the warranty and expose the user to the risk of personal injury. Do not confuse the markings on a filter relating to any standard other than Australian/New Zealand standard AS/NZS 1716:2012 with the classification PAPR-P3 of PAPR-P3 device when used with this filter.)
4. Change the pre-filter if needed.
5. If necessary, clean or change the part arrestor (metal net) on the base of the filter cover.
6. Put back the filter cover, with the filter installed, by hooking the cover on the left side of the PAPR-P3 unit, and pressing the cover down so that the latch engages correctly.

WARNING: Check the expiry date of the unopened filter. DO NOT use it if it's expired.

Only the PAPR-P3 particle filter, gas filter and pre-filter can be used together with this system. Filters from other manufacturers should under no circumstances be used.

MAINTENANCE & STORAGE

Inspect the equipment daily, and always check it if any sign of malfunction occurs.

MAINTENANCE

- The PAPR unit must be checked regularly and must be changed if it is damaged or caused leakage.
- The filter must be changed if it is broken, or it is blocked and does not give enough airflow.
- The breathing tube must be changed if it is broken or has a crevasse.
- The battery must be charged when the low battery alarm rings.
- Use a soft cloth to wipe the external surfaces. Don't use water!
- The filter should be replaced together with the pre-filter.

STORAGE

- The PAPR must be stored in a dry, clean area, in the temperature range of -10°C to +55°C and relative humidity less than 90%RH.
- If the equipment is stored at temperature below 0°C, the battery must be allowed to warm up to achieve full battery capacity. The equipment must be protected from dust, particles and other contamination.
- If the equipment is not used for a long time, the battery should be full charged, removed from PAPR unit and store separately.

PAPR WELDING HELMET PARTS LIST

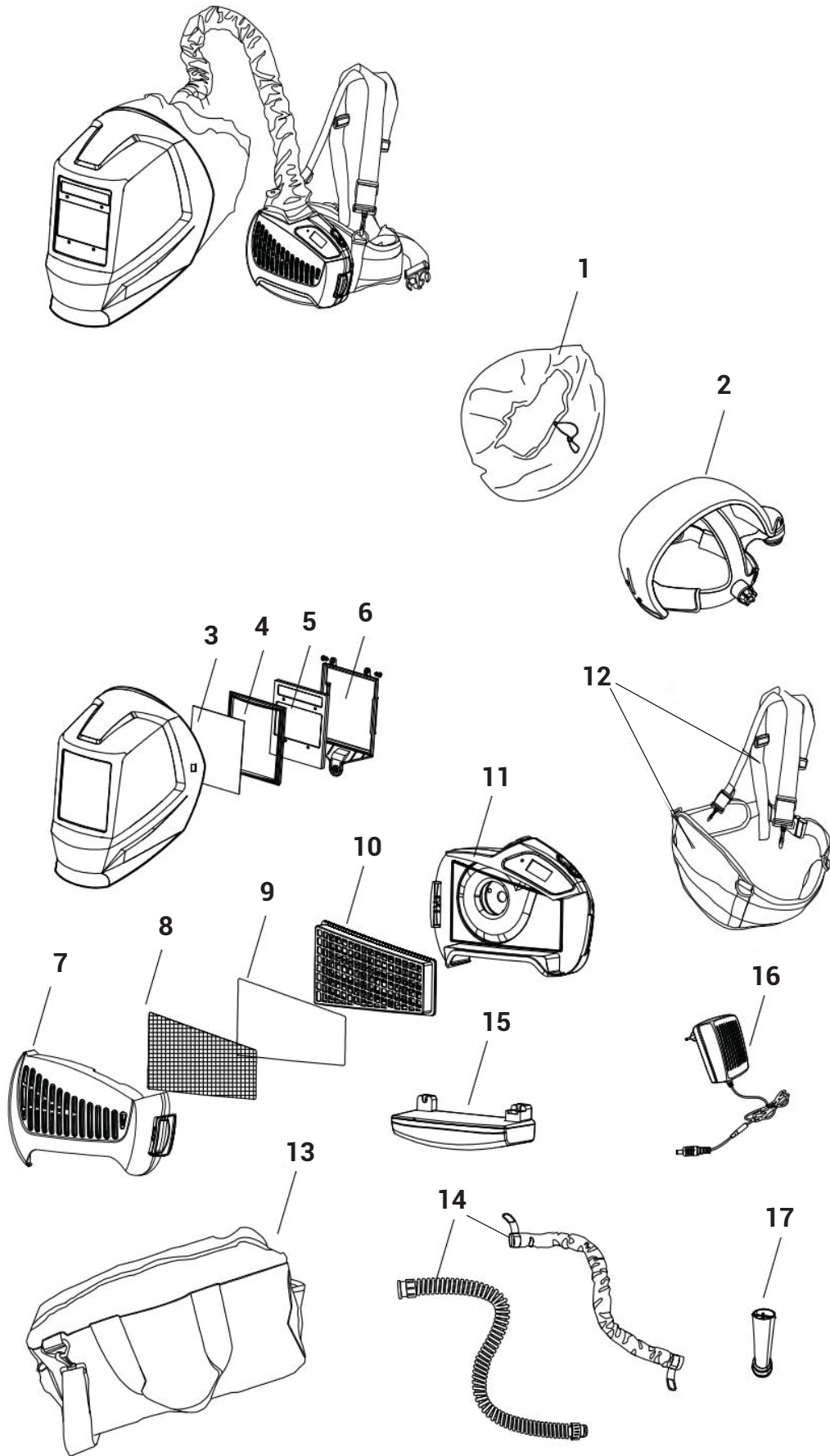

PAPR WELDING HELMET PARTS LIST



DRAWING NO.	PART NO.	DESCRIPTION	MFG DATE
1	XA-P0102-P3	Face Seal P3	
2	XA-P0201-P3	Air duct P3	
3	XA-FCL133-114	Outer Protection Lens Pack	
4		ADF Cradle	
5		Auto-Darkening Filter(ADF)	
6	XA-AS7-1-ICL	Inner Protection Lens	
7	XA-P0401	Filter Cover	
8	XA-P0402	Spark Arrestor	
9	XA-P0403	Pre-filter	
10	XA-P0404	Filter	
11	XA-P0405	Turbo Unit	
12	XA-P0501	Waist Belt & Shoulder Harness	
13	XA-P0503	Carry Bag	
14	XA-P0601-P3	Xcel-Arc PAPR Breathing Tube & Anti-fire Cloth of Breathing Tube	
15	XA-P0301	Rechargeable Battery	
16	XA-P0603	Battery Charger	
17	XA-P0604	Air Flow Tester	

PAPR WELDING HELMET

PAPR UNIT TROUBLESHOOTING

PROBLEM	PROBABLE CAUSE	ACTION
LCD defective code E01 and red light flashes	<ul style="list-style-type: none"> Motor is stuck Motor damage Blower structure failure caused by outer force Circuit failure 	Check and remove physical failure and restart the system. Return to dealer if LCD still shows E01
LCD defective code E02 and red light flashes	<ul style="list-style-type: none"> Motor damage Motor impeller rubs blower shell Circuit overheating 	Check and remove physical failure and restart the system. Return to dealer if LCD still shows E02
LCD battery icon flashes Warning sound Red light flashes	<ul style="list-style-type: none"> Low battery 	Charge the battery
LCD filter icon flashes Warning sound Red light flashes	<ul style="list-style-type: none"> Filter blocked Hose blocked 	<ul style="list-style-type: none"> Remove obstruction, change the filter Clean hose
LCD temperature icon flashes Warning sound Red light flashes	<ul style="list-style-type: none"> High temperature 	Stop working and rest
No flow, no alarm	<ol style="list-style-type: none"> 1. No power 2. Battery contact damaged 	<ul style="list-style-type: none"> Charge the battery Check battery contact
Battery run time is too short	<ol style="list-style-type: none"> 1. Battery is not fully charged 2. Filter is blocked 3. Battery is damaged 	<ul style="list-style-type: none"> Charge the battery Remove obstruction, Change filter Change battery
Air supply to hood smells unusual	<ol style="list-style-type: none"> 1. Filter broken 2. Hose broken 3. ADF helmet broken 	<ul style="list-style-type: none"> Leave current area immediately. 1. Change filter 2. Change hose 3. Change ADF helmet
Supply insufficient air to hood	<ol style="list-style-type: none"> 1. Breathing tube break off 2. Breathing tube broken 3. Filter is blocked 	<ol style="list-style-type: none"> 1. Check hose connect to hood and PAPR unit 2. Change breathing tube 3. Remove obstruction, change filter

HELMET TROUBLESHOOTING

PROBLEM	SOLUTION
The ADF does not darken when welding	<ul style="list-style-type: none"> • Stop welding or cutting immediately. • Make sure the sensors are facing the arc and there are no obstructions. • Check the mode is on WELD, not GRIND. • Review sensitivity recommendations and adjust sensitivity if possible. • Replace the battery if necessary.
The ADF stays dark after welding or there is no arc present	<ul style="list-style-type: none"> • Adjust the sensitivity to a lower level. • If the work-site is too bright, it is recommended to reduce the surrounding light level.
The ADF switches during the welding	<ul style="list-style-type: none"> • Increase the sensitivity if possible. • Make sure the sensors are facing the arc and there are no obstructions. • Increase Delay 0.1 – 0.3 seconds may also reduce switching.
Inconsistent shade number on the corner of ADF	<ul style="list-style-type: none"> • It is a natural feature and will not be dangerous for the eyes. • To get maximum comfort, try to keep a view angle at around 90°.

RECOMMENDED SHADE SETTINGS

		Current Amperes																							
		0.5	1	2.5	5	10	15	20	30	40	50	60	100	125	150	175	200	225	250	275	300	350	400	450	500
Welding Process	Covered Electrode	Shade 9								Shade 10	Shade 11				Shade 12				Shade 13			14			
	MIG Plate Welding	Shade 10										Shade 11			Shade 12			Shade 13			14				
	MIG Sheet Metal	Shade 10										Shade 11			Shade 12		Shade 13		Shade 14		15				
	TIG	Shade 9						Shade 10	Shade 11			Shade 12		Shade 13		Shade 14									
	MAG	Shade 10										Shade 11	Shade 12	Shade 13			Shade 14		Shade 15						
	Arc Gouging	Shade 10												Shade 11	Shade 12	Shade 13	Shade 14	Shade 15							
	Plasma Cutting	Shade 11										Shade 12			Shade 13										
	Plasma Welding	4	5	6	7	8	9	Shade 10	Shade 11	Shade 12		Shade 13		Shade 14			Shade 15								

PAPR WELDING HELMET

SPECIFICATION

Size (Blower Assembly)	9-2/5 x 6-1/2 x 2-3/4 in. (240 x 165 x 70 mm)
Weight	2.4kg
Air Filter	1*P3
Air Flow	Level 1: >=170L/min Level 2: 200L/min Level 3: 230L/min
Noise Level	Max 75dB
Operating Temperature	23°C to 131°C (-5°C~55°C)
Storage temperature	14°C to 131°C (-10°C~55°C)
Battery Type	Rechargeable Li-ION 4400mAh
Expected Battery Operation Time	Level 1 >10h Level 2 >8h Level 3 >6h
Battery Charging Time	3.5 Hours
Battery Life	500 Charges Run Time Dependent On Air Flow Rate and Filter Load.
LCD Display	Air flow level and data Battery capacity Filter status
Belt Size	35-2/5 x 51-2/5 in. (900mm to 1300mm)

MARKING EXPLANATION

POWERED FILTERING DEVICE:

Australian/New Zealand standard AS/NZS 1716:2012 Respiratory protective devices - Powered filtering devices incorporating a helmet or hood – Requirements, testing, marking.

P3/TH3 P R(SL) classification of the unit. "TH3" defines the level of protection, "PR" indicates the filter type ("P"= Particle filter, "R"= Reusable type of particle filters) and "SL" reflects

the filter has been tested against particles of liquid and solid matter.

WARNING SOUND INDICATION

Each grid stands for a period of 100ms. Grey is the beep sound and blank grid is a quiet period. If several continued grids are in grey then there's a continuous beep sound.

For example, when the current is overloaded, the system sounds like beep~ beep~beep~~~~~.

100ms per grid											
	0	1	2	3	4	5	6	7	8	9	10
Install the battery											
Turn on the system											
Change the air flow speed											
Turn off the system											
Current overload											
Air outlet jam											
Over heat											
Low battery											
Filter jam											



Read instructions before use

CE 2797

CE mark followed by number of notified body who carried out module D surveillance.

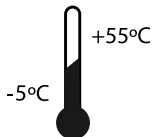

The system should be operated in the temperature range of -5°C to +55°C



The system should be operated in an environment with relative humidity less than 90%RH

WARRANTY

- The PAPR-P3 Helmet is guaranteed for a period of 24 months from date of purchase.
- The PAPR-P3 Blower unit is guaranteed for a period of 12 months from date of purchase against mechanical or electrical defects.
- The PAPR-P3 battery is guaranteed for a period of 6 months from the date of purchase.
- The company undertakes to exchange or repair without charge, any part found to be defective within this period. Alternatively and at its discretion. The company may replace.

This guarantee is subject to:

- The PAPR-P3 unit has been used solely for the purpose for which it is intended.
- The PAPR-P3 unit has not been subject to misuse, accident, modification or repair.

N.B. In the event of a claim, contact the retailer from which the PAPR-P3 unit was purchased. The guarantee does not cover normal wear and tear, this guarantee does not affect your legal rights.



Esseti New Zealand Limited

PO Box 4189, Palmerston North - 4442

Phone: 06 355 1103

Fax: (06) 354 2437

Email: sales@esseti.co.nz

www.esseti.co.nz